

International Tube & Conduit Company Ltd.



## UL STEEL CONDUITS & FITTINGS



# ABOUT THE COMPANY



ITCC is a major manufacturer of Steel Conduits, Steel Tubes, Scaffolding and Construction Props, as well as fence materials. It operates a state-of-the-art manufacturing and assembly facility located in bKing Abdullah Economic City. ITCC also uses the latest technologies to produce defect-free and high quality products and services meeting the needs of customers across different segments.



## COMPANY PROFILE

ITCC produces the following range of products:

- Electrical conduits: EMT, IMC, RMC, BS 31, BS 4568, FC & Fittings
- PVC Coated Rigid Steel Conduits & Fittings
- Schedule 40 Pipes
- Tubes and hollow sections: round, square and rectangular

## VISION STATEMENT

We strive to exceed our customer's expectations through leading edge technologies and managerial advanced production solutions. ITCC is committed to adding value, achieving trust, creativity and innovation in providing galvanized and coated steel tubes.



Within ITCC - We are committed to providing products and services with timely delivery and of high quality; meeting all our Customer's specifications. We are committed to setting and achieving quality standards that meet the specified requirements and expectations of our customers taking into account the evolvement of needs and expectations.

ITCC developed a Quality Management System that conforms to the ISO 9001:2015 requirements in addition to other regulatory requirements, directives, and standards appropriate for business such as UL Standards, EC Marking, DIN and BS Directives. The Quality Management System (QMS) enables our organization to provide and consistently maintain high quality on all undertaken work. Our QMS ensures that proper communication, work control, and accountable traceability records are generated for all undertaken work. At ITCC employees are tasked with promoting these aims, and are required to adhere to our Quality manual. Our manual defines the Quality Management System that has been adopted as the means for achieving our organization's business objectives, via regular Management Review. All parties, supplier and subcontractors co-operating with ITCC, receive support to conform to our strict QMS. Our Quality Assurance Manager is the appointed management representative responsible for monitoring and ensuring the correct and effective implementation of ITCC Quality Management System as a whole. The principles of Total Quality Management, especially continuous improvement, are applied to every aspect of our activities. Quality is the responsibility of everyone, and in every activity throughout the organization. This quality policy provides the framework for establishing quality objectives, which are integrated into the company's strategic plan.

ZINC-TECH IN-LINE HOT DIPPED GALVANIZED PRODUCT

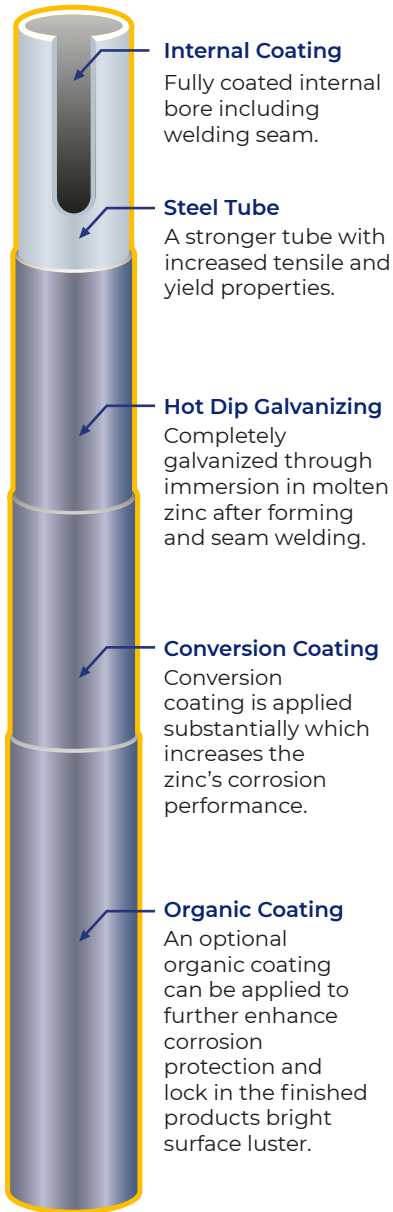

Comparative table between Hot Dipped Zinc-Tech, and Hot Dipped Conventional Process

The characteristics of the Hot Dipped Zinc-Tech™ Process also provides yet another distinct and very beneficial property as your finished product, an increase in both tensile and yield strength.

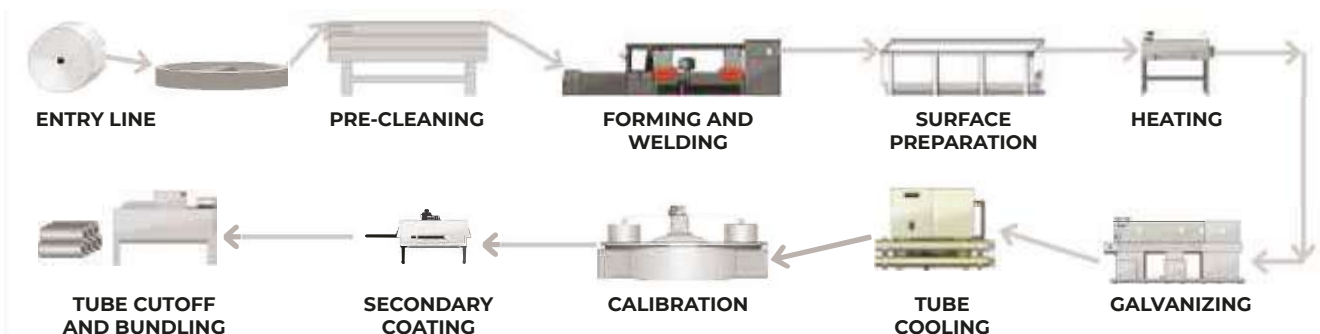
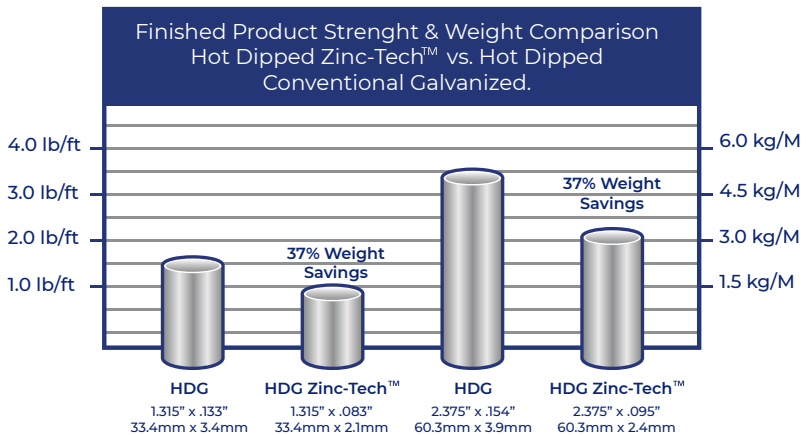
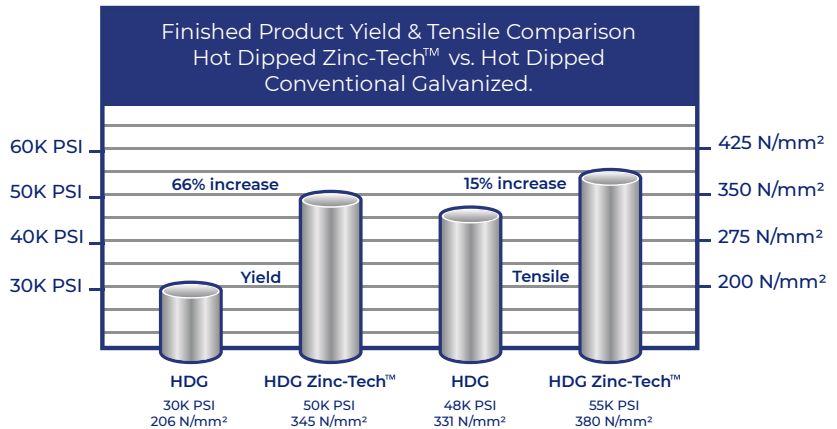



Certificate SA10/2156

The management system of

# International Tube and Conduit Company Ltd.

King Abdulla Economic City-Western Region, P.O Box 10374,  
Jeddah, 21433, Saudi Arabia

has been assessed and certified as meeting the requirements of



## ISO 9001:2015

For the following activities

**Manufacture, Sales and Distribution of Galvanized Steel Conduits,  
Steel Tubes, Scaffolding, Props, Formworks and Fencing Products and  
Accessories.**

This certificate is valid from 1 April 2022 until 1 April 2025  
and remains valid subject to satisfactory surveillance audits.  
Recertification audit due a minimum of 60 days before the expiration date.  
Issue 6. Certified since 1 April 2010



Authorised by



0005

SGS United Kingdom Ltd  
Rossmore Business Park Ellesmere Port Cheshire CH65 3EN UK  
t +44 (0)151 350-6666 f +44 (0)151 350-6600 [www.sgs.com](http://www.sgs.com)

21HC 9001 2015 0421

Page 1 of 1



This document is issued by the Company subject to its General Conditions of Certification Services accessible at [www.sgs.com/terms\\_and\\_conditions.htm](http://www.sgs.com/terms_and_conditions.htm). Attention is drawn to the limitations of liability, indemnification and jurisdictional issues established therein. The authenticity of this document may be verified at <http://www.sgs.com/en/certified-clients-and-products/certified-client-directory>. Any unauthorized alteration, forgery or falsification of the content or appearance of this document is unlawful and offenders may be prosecuted to the fullest extent of the law.





# TABLE OF CONTENTS

<b>STEEL CONDUITS .....</b>	<b>8</b>
<b>EMT FITTINGS &amp; ELBOWS .....</b>	<b>15</b>
<b>IMC/RMC FITTINGS &amp; ELBOWS .....</b>	<b>24</b>
<b>CONDUIT BODIES .....</b>	<b>41</b>
<b>FLEXIBLE METALLIC CONDUIT FITTINGS.....</b>	<b>46</b>
<b>UTILITY BOXES AND COVERS .....</b>	<b>50</b>
<b>STRUT CHANNELS AND ACCESSORIES .....</b>	<b>54</b>
<b>MISCELLANEOUS ACCESSORIES .....</b>	<b>57</b>
<b>PVC COATED RMC CONDUITS &amp; FITTINGS .....</b>	<b>63</b>
<b>PROJECT REFERENCE .....</b>	<b>79</b>



ITCC



**STEEL CONDUITS**



## CONDUITS

Electrical Metallic Tubing  
Rigid Metal Conduit  
Intermediate Metal Conduit  
Flexible Conduit  
Fittings

EMT  
RMC  
IMC  
FC

Steel conduits are recognized as providing the most mechanical protection to the enclosed wire conductors. It is also recognized as an equipment grounding conductor.

We at ITCC produce our conduit by rolling our own tubing from high grade mild steel strips, welding and hot dip galvanizing it; using our own Zinc-Tech process that combines Zinc, a conversion coat and an organic coating.

The inside of the conduits have a corrosion resistant lubricating coating for easier wire pulling.

### **The resulting conduit has the following superior characteristics:**

- The best corrosion performance of any galvanized product.
- Increased tensile and yield for a stronger product.
- Better fabrication properties: cutting, bending and welding.
- Meets the Underwriters Laboratories Specification UL6, UL797 and UL1242 where applicable.
- A far superior finish and product appearance.
- Easy wire pulling.
- Provides shielding magnetic field.

**EMT is a steel raceway of circular cross section which is unthreaded. The exterior is galvanized and protected by a clear zinc coating. The interior is a smooth continuous raceway and is coated with zinc organic lubricants. It is installed either indoors or outdoors in all conditions and produced trade size from 1/2" to 4".**

**EMT Pipes are manufactured in accordance with the latest edition of the following:**

- Underwriters Laboratories Standard for Electrical Metallic Tubing (UL 797). File No. E331698

**Save with the length when purchasing the 6M EMT:**

- 6M (EMT) 20 feet
- Fewer fittings
- Quick and easy installation
- Listed to UL 797 Standard



### ELECTRICAL METALLIC TUBING - STEEL (WEIGHTS AND DIMENSIONS)

Code	Trade Size	Metric Designator	Wall Thickness mm.	Outside Diameter mm.	Weights of 10 Units Lengths kg.
C-E00050	1/2"	16	1.07	17.93	12.90
C-E00075	3/4"	21	1.24	23.42	19.70
C-E00100	1"	27	1.45	29.54	29.00
C-E00125	1 1/4"	35	1.65	38.35	43.10
C-E00150	1 1/2"	41	1.65	44.20	49.90
C-E00200	2"	53	1.65	55.80	63.50
C-E00250	2 1/2"	63	1.83	73.03	93.10
C-E00300	3"	78	1.83	88.90	113.50
C-E00350	3 1/2"	91	2.11	101.60	147.50
C-E00400	4"	103	2.11	114.30	167.90

NOTES: Applicable tolerances

Length: 10ft. +/- 1/4 in. (+/- 6.35 mm)

(1) Outside Diameter: 2 -2+/- 10.015/in. (0.13 -/+35 -16mm), 2+/- 10.020 - 2/in. (-103 +/- 910.52 mm), 0.015 -/+ 3in. (0.38 -/+ 78 mm), 2-4+/- 10.020 - 3/in. (-103 +/- 910.51 mm).

Colors Available:



**RMC is a threaded metal raceway of circular cross sections with coupling which can either be standard straight tapped conduit or integral type. It is known as the heaviest weight and thickest steel conduit. It has a coating of zinc on both outside and inside surfaces. It is also non combustible and can be used indoors, outdoors, underground, concealed or exposed areas.**

**RMC Pipes are manufactured in accordance with the latest edition of the following:**  
 • Underwriters Laboratories Standard for Electrical Rigid Metal Conduit (UL 6). File No. E331696

**Save with the length when purchasing the 6M RMC:**

- 6M (EMT) 20 feet
- Fewer fittings
- Quick and easy installation
- Listed to UL 6 Standard



### RIGID METAL CONDUIT - STEEL (WEIGHTS AND DIMENSIONS)

Code	Trade Size	Metric Designator	Wall Thickness mm.	Outside Diameter mm.	Length of Straight Conduit 6+ mm.	Min. Weight of 10 Pcs. Screwed & Coupled kg.
C-R00050	1/2"	16	2.64	21.34 ± 0.38	3050	35.8
C-R00075	3/4"	21	2.72	26.67 ± 0.38	3050	47.6
C-R00100	1"	27	3.2	33.4 ± 0.38	3050	69.4
C-R00125	1 1/4"	35	3.38	42.16 ± 0.38	3050	91.2
C-R00150	1 1/2"	41	3.51	48.26 ± 0.38	3050	112.9
C-R00200	2"	53	3.71	60.33 ± 0.603	3050	150.6
C-R00250	2 1/2"	63	4.9	73.03 ± 0.73	3050	239
C-R00300	3"	78	5.21	88.9 ± 0.889	3050	309.6
C-R00350	3 1/2"	91	5.56	101.6 ± 1.016	3050	376.9
C-R00400	4"	103	5.72	114.3 ± 1.14	3050	441
C-R00500	5"	129	6.2	141.3 ± 1.1413	3050	595.9
C-R00600	6"	155	6.75	168.26 ± 1.682	3050	791.7

Conduits up to 6" are UL Listed (UL6)

Colors Available:

PVC coated Rigid Conduits available upon request

**Made of high quality flat rolled steel and produced using an electric resistance welding process. Listed threaded steel raceway of circular cross sections with the coupling which can be either a standard straight-tapped conduit or integral type. Moreover, interchangeable with galvanized rigid steel conduit, they both have the same threads, use the couplings and fittings and als are permitted to be used in the same locations.**

**IMC Pipes are manufactured in accordance with the latest edition of the following:**

- Underwriters Laboratories Standard for Electrical Intermediate Metal Conduit - Steel (UL 1242). File No. E331697

**Save with this weight:**

IMC weights about one third less than rigid metal conduit and has a larger interior diameter.

**Save with the length when purchasing the 6M IMC:**

- 6M (EMT) 20 feet
- Fewer fittings
- Quick and easy installation
- As per UL 1242 Standard



## INTERMEDIATE METAL CONDUIT - STEEL (WEIGHTS AND DIMENSIONS)

Code	Trade Size	Metric Designator	Wall Thickness mm.	Outside Diameter mm.	Inside Diameter mm.	Length of Straight Conduit mm.
C-I00050	1/2"	16	1.97	20.70	16.76	3050
C-I00075	3/4"	21	2.10	26.13	22.07	3050
C-I00100	1"	27	2.35	32.77	28.07	3050
C-I00125	1 1/4"	35	2.42	41.59	36.77	3050
C-I00150	1 1/2"	41	2.54	47.82	42.74	3050
C-I00200	2"	53	2.67	59.93	54.60	3050
C-I00250	2 1/2"	63	3.81	72.57	64.95	3050
C-I00300	3"	78	3.81	88.29	80.67	3050
C-I00350	3 1/2"	91	3.81	100.86	93.24	3050
C-I00400	4"	103	3.81	113.44	105.82	3050

NOTES: (1) Figures are the average of the maximum and minimum dimensions as given in **UL 1242**  
 (2) Calculated from nominal outside diameter and nominal wall thickness.  
 (3) From 2 1/2" and higher, figures are hot-dip galvanized conduit.

Colors Available:



**Galvanized steel flexible conduit is suitable for concealed, exposed or approved raceways. The flexible conduit is manufactured with a continuous spiral wound strip corrosion rust resistant, hot dipped galvanized steel. The natural color type RWS conduit features a smooth metal interior for easy wire plugging. The flexible steel conduit is wire temperature rated, and has a superior crush proof qualities.**

#### **Its Benefits:**

- Smooth interior for easy wire pulling
- Able to withstand high temperatures
- Durable crush-proof construction
- Corrosion and rust resistant

#### **Applications:**

- Motor Feeder, Branch, Control circuit conductors and cable
- Environmental air-handling spaces.
- Concealed or exposed installations
- Elevators, hoistways escalators

### **FLEXIBLE METAL CONDUIT - STEEL (WEIGHTS AND DIMENSIONS)**

Code	Trade Size	Internal Diameter		Outside Diameter			Min. Bending Radius mm	Length of Conduit (M/Roll)
		Min.	mm. Max.	Min.	mm. Max.	Max.		
C-FC0050	1/2"	15.8	16.2	19.5	19.9	65	30	
C-FC0075	3/4"	20.8	21.3	24.7	25.2	75	30	
C-FC0100	1"	26.4	27.1	31.6	32.1	100	15	
C-FC0125	1 1/4"	35.0	35.5	40.0	40.5	125	15	
C-FC0150	1 1/2"	40.1	40.6	45.8	46.3	150	10	
C-FC0200	2"	50.5	51.2	57.3	58.0	175	7.5	

\*Other sizes are also available upon request



**Construction**

Galvanized Steel strips (0.3MM thickness), helically wound. Square lock flexible conduit with heavy smooth PVC cover coating, strong square lock, IP Rating: IP66 + IP67 + IP68. Available in Black and Gray Colors.

**PVC**

The PVC is keyed into the corrugations of the inner steelv flexible core, which prevents the PVC from wrinkling when the conduit is bent to its minimum bend radius. The PVC coating provides a smooth outer surface onto which liquid tight compression fittings can be secured.

**Special features:**

- PVC Cover will have minimal wrinkle when bend.
- Resistant to oils and greases.
- Temperature range -20C to +90C.
- UV resistant and suitable for external use.

**Applications:**

- Indoor and Outdoor installations where liquid tight proofing is required.
- Cable management for conveyors, blowers, crane hoist, HVAC, machine and equipments etc.
- Designed for both commercial and industrial applications.

**LIQUID TIGHT FLEXIBLE CONDUIT (WEIGHTS AND DIMENSIONS)**

Code	Trade Size	Internal Diameter		Outside Diameter			Min. Bending Radius mm	Length of Conduit (M/Roll)
		Min.	mm. Max.	Min.	mm.	Max.		
C-FLTC050	1/2"	15.80	16.31	20.83	21.34	85	30	
C-FLTC075	3/4"	20.83	21.34	26.16	26.67	100	30	
C-FLTC100	1"	26.44	27.08	32.77	33.40	120	30	
C-FLTC125	1 1/4"	35.05	35.81	41.40	42.16	150	15	
C-FLTC150	1 1/2"	40.00	40.64	47.37	48.26	180	15	
C-FLTC200	2"	51.31	51.94	59.44	60.33	220	15	

\*Other sizes are also available upon request

ITCC



**EMT FITTINGS & ELBOWS**



## EMT Connectors and Couplings

### Set Screw Type Connector Zinc Die Cast

**Features:**

- Set screw type connector
- Concrete tight when taped
- Assembled with a die cast locknut
- Available with insulated throat

**Applications:**

- Connectors; use joint EMT to box or enclosure
  - Couplings; use to joint two lengths of EMT
- Standard Material**
- Zinc die cast

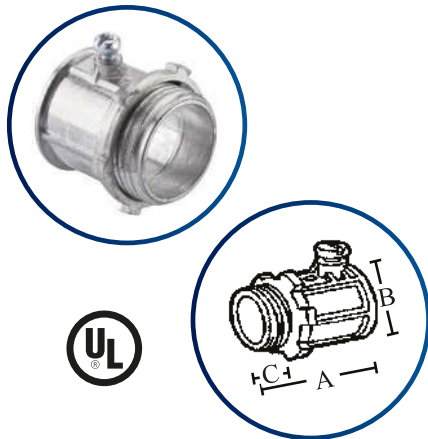

Catalog Number	Size	Unit Carton	Ship Case	Dimensions (in)		
				A	B	C
CZ-CN0050	1/2"	50	500	1.063	0.728	0.335
CZ-CN0075	3/4"	25	250	1.339	0.954	0.394
CZ-CN0100	1"	—	50	1.496	1.181	0.512
CZ-CN0125	1 1/4"	—	25	1.772	1.555	0.512
CZ-CN0150	1 1/2"	—	25	1.969	1.772	0.551
CZ-CN0200	2"	—	20	2.323	2.225	0.630
CZ-CN0250	2 1/2"	—	12	2.953	2.913	0.954
CZ-CN0300	3"	—	12	3.307	3.543	0.984
CZ-CN0350	3 1/2"	—	10	3.460	4.460	1.050
CZ-CN0400	4"	—	6	3.740	4.567	1.063

### Set Screw Type Connector with Insulated Throat - Zinc Die Cast

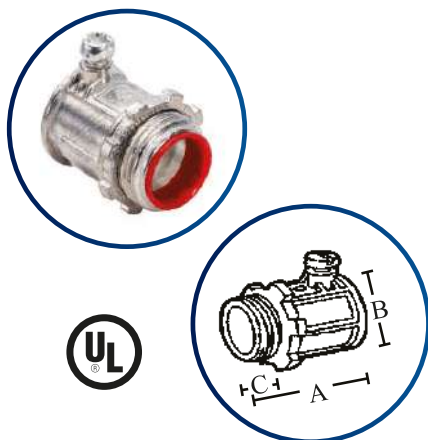

Catalog Number	Size	Unit Carton	Ship Case	Dimensions (in)		
				A	B	C
CZI-CN0050	1/2"	50	500	1.063	0.728	0.335
CZI-CN0075	3/4"	25	250	1.339	0.954	0.394
CZI-CN0100	1"	50	200	1.496	1.181	0.512
CZI-CN0125	1 1/4"	—	25	1.772	1.555	0.512
CZI-CN0150	1 1/2"	—	25	1.969	1.772	0.551
CZI-CN0200	2"	—	20	2.323	2.225	0.630
CZI-CN0250	2 1/2"	—	12	2.953	2.913	0.954
CZI-CN0300	3"	—	12	3.307	3.543	0.984
CZI-CN0350	3 1/2"	—	10	3.460	4.460	1.050
CZI-CN0400	4"	—	6	3.740	4.567	1.063

### Set Screw Type Coupling - Zinc Die Cast

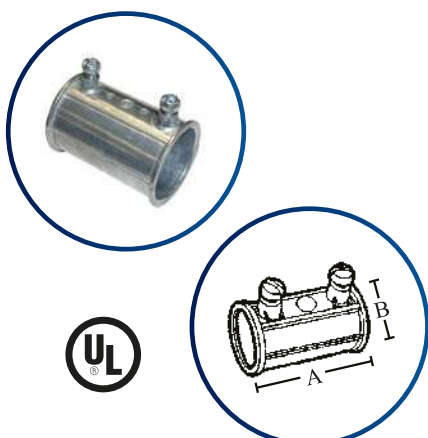

Catalog Number	Size	Unit Carton	Ship Case	Dimensions (in)	
				A	B
CZ-CP0050	1/2"	50	500	1.457	0.728
CZ-CP0075	3/4"	25	250	1.811	0.945
CZ-CP0100	1"	50	200	1.969	1.181
CZ-CP0125	1 1/4"	—	25	2.402	1.555
CZ-CP0150	1 1/2"	—	25	2.717	1.772
CZ-CP0200	2"	—	20	3.228	2.225
CZ-CP0250	2 1/2"	—	12	4.016	2.913
CZ-CP0300	3"	—	12	4.488	3.543
CZ-CP0350	3 1/2"	—	10	4.850	4.520
CZ-CP0400	4"	—	6	5.061	4.567

## EMT Connectors and Connector Couplings

### Compression Type Connector Zinc Die Cast

**Features:**

- Compressed type connector
- Concrete tight
- Assembled with a die cast locknut
- Available with insulated throat

**Applications:**

- Connectors; use joint EMT to box or enclosure
  - Couplings; use to joint two lengths of EMT
- Standard Material**
- Zinc die cast

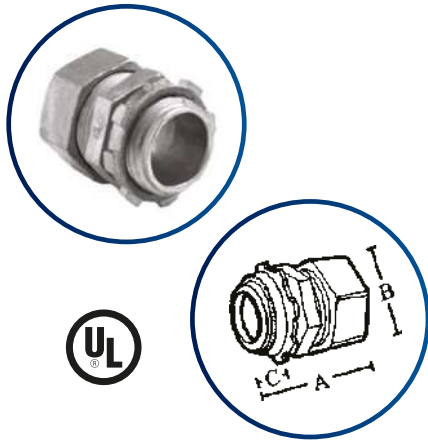

Catalog Number	Size	Unit Carton	Ship Case	Dimensions (in)		
				A	B	C
CZ-CCN050	1/2"	50	500	1.200	0.720	0.370
CZ-CCN075	3/4"	25	250	1.260	0.940	0.390
CZ-CCN100	1"	50	200	1.420	1.180	0.470
CZ-CCN125	1 1/4"	—	25	1.650	1.560	0.550
CZ-CCN150	1 1/2"	—	20	1.810	1.770	0.590
CZ-CCN200	2"	—	15	2.050	2.220	0.710
CZ-CCN250	2 1/2"	—	12	2.630	2.630	0.860
CZ-CCN300	3"	—	12	2.770	2.770	1.010
CZ-CCN350	3 1/2"	—	10	2.770	2.770	0.940
CZ-CCN400	4"	—	6	2.770	2.770	1.000

### Compression Type Connector with Insulated Throat - Zinc Die Cast

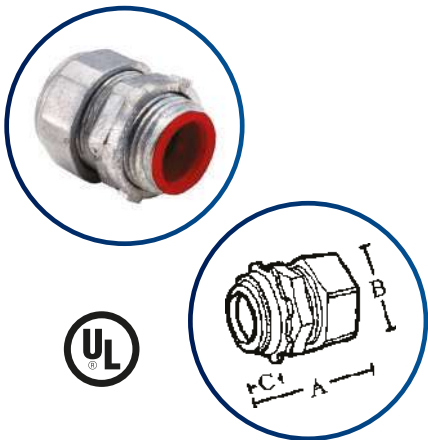

Catalog Number	Size	Unit Carton	Ship Case	Dimensions (in)		
				A	B	C
CZI-CCN050	1/2"	50	200	1.200	0.720	0.370
CZI-CCN075	3/4"	25	250	1.260	0.940	0.390
CZI-CCN100	1"	50	200	1.420	1.180	0.470
CZI-CCN125	1 1/4"	—	25	1.650	1.560	0.550
CZI-CCN150	1 1/2"	—	20	1.810	1.770	0.590
CZI-CCN200	2"	—	15	2.050	2.220	0.710
CZI-CCN250	2 1/2"	—	12	2.630	2.630	0.860
CZI-CCN300	3"	—	12	2.770	2.770	1.010
CZI-CCN350	3 1/2"	—	10	2.770	2.770	0.940
CZI-CCN400	4"	—	6	2.770	2.770	1.000

### Compression Type Coupling - Zinc Die Cast

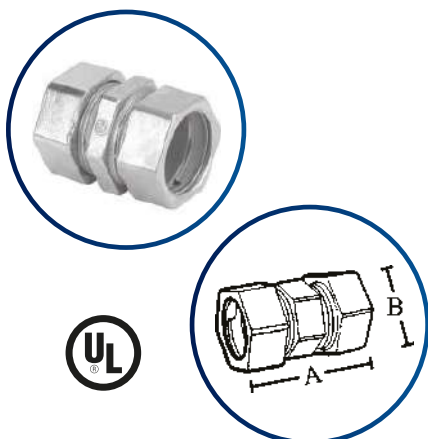

Catalog Number	Size	Unit Carton	Ship Case	Dimensions (in)	
				A	B
CZ-CCP050	1/2"	50	500	1.500	0.730
CZ-CCP075	3/4"	25	250	1.540	0.940
CZ-CCP100	1"	50	200	1.610	1.180
CZ-CCP125	1 1/4"	—	25	1.850	1.560
CZ-CCP150	1 1/2"	—	20	2.090	1.770
CZ-CCP200	2"	—	15	2.200	2.220
CZ-CCP250	2 1/2"	—	12	3.290	3.700
CZ-CCP300	3"	—	12	3.420	4.490
CZ-CCP350	3 1/2"	—	10	3.510	5.060
CZ-CCP400	4"	—	6	3.540	5.630

## EMT Connectors and Couplings

### Set Screw Type Connector Steel

**Features:**

- Set screw type connector and couplings
- Concrete tight when taped
- Assembled with a steel locknut
- Available with insulated throat

**Applications:**

- Connectors; use joint EMT to box or enclosure
- Couplings; use to joint two lengths of EMT

**Standard Material**

- Steel
- Standard Finish**
- Zinc plated

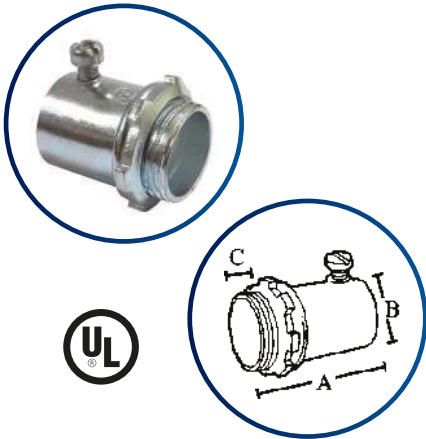

Catalog Number	Size	Unit Carton	Ship Case	Dimensions (in)		
				A	B	C
C-CN050	1/2"	50	500	1.531	1.313	0.438
C-CN075	3/4"	25	250	1.625	1.563	0.469
C-CN100	1"	50	200	2.250	1.938	0.563
C-CN125	1 1/4"	—	25	2.500	2.250	0.563
C-CN150	1 1/2"	—	25	2.750	2.750	0.563
C-CN200	2"	—	20	3.313	3.563	0.750
C-CN250	2 1/2"	—	12	3.813	4.188	0.938
C-CN300	3"	—	12	3.938	4.688	0.938
C-CN350	3 1/2"	—	6	4.188	5.188	1.000
C-CN400	4"	—	6	3.750	1.050	4.990

### Set Screw Type Connector with Insulated Throat - Steel

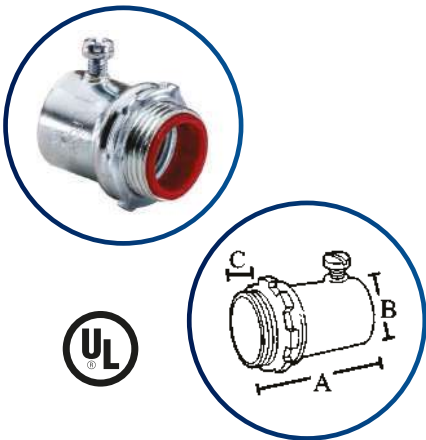

Catalog Number	Size	Unit Carton	Ship Case	Dimensions (in)		
				A	B	C
C-CNI050	1/2"	50	500	1.531	1.313	0.438
C-CNI075	3/4"	25	250	1.625	1.563	0.469
C-CNI100	1"	50	200	2.250	1.938	0.563
C-CNI125	1 1/4"	—	25	2.500	2.250	0.563
C-CNI150	1 1/2"	—	25	2.750	2.750	0.563
C-CNI200	2"	—	20	3.313	3.563	0.750
C-CNI250	2 1/2"	—	12	3.813	4.188	0.938
C-CNI300	3"	—	12	3.938	4.688	0.938
C-CNI350	3 1/2"	—	6	4.188	5.188	1.000
C-CNI400	4"	—	6	3.750	1.050	4.990

### Set Screw Type Coupling - Steel

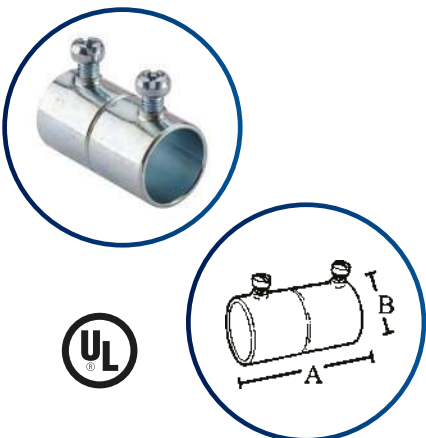

Catalog Number	Size	Unit Carton	Ship Case	Dimensions (in)	
				A	B
C-CP050	1/2"	50	500	1.750	0.880
C-CP075	3/4"	25	250	2.215	1.060
C-CP100	1"	10	100	2.500	1.310
C-CP125	1 1/4"	—	25	3.250	1.690
C-CP150	1 1/2"	—	25	3.750	1.940
C-CP200	2"	—	20	4.000	2.380
C-CP250	2 1/2"	—	12	4.250	3.190
C-CP300	3"	—	12	4.500	3.190
C-CP350	3 1/2"	—	6	4.750	4.310
C-CP400	4"	—	6	5.000	4.810

## EMT Connectors and Couplings

### Compression Type Connector Steel

**Features:**

- Compression type connector and couplings
- Concrete tight
- Assembled with a steel locknut
- Available with insulated throat

**Applications:**

- Connectors; use joint EMT to box or enclosure
- Couplings; use to joint two lengths of EMT

**Standard Material**

- Steel
- Standard Finish**
- Zinc plated

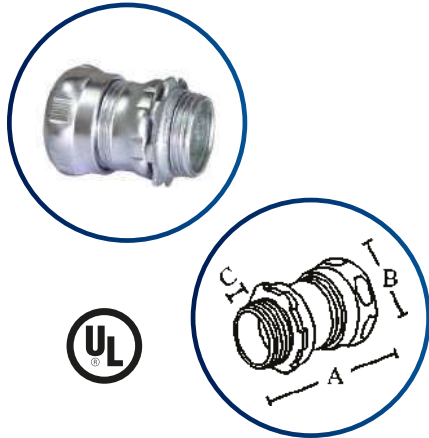

Catalog Number	Size	Unit Carton	Ship Case	Dimensions (in)		
				A	B	C
C-CCN050	1/2"	25	250	1.4567	0.7087	0.4567
C-CCN075	3/4"	25	250	1.4843	0.9252	0.4567
C-CCN100	1"	10	100	1.6535	1.1811	0.6024
C-CCN125	1 1/4"	—	25	1.4961	1.5118	0.6850
C-CCN150	1 1/2"	—	20	2.4409	1.7559	0.7323
C-CCN200	2"	—	15	2.3622	2.2047	0.7323
C-CCN250	2 1/2"	—	12	2.3800	2.8800	0.8800
C-CCN300	3"	—	6	2.8800	3.5200	0.8800
C-CCN350	3 1/2"	—	6	3.0000	4.0000	1.0000
C-CCN400	4"	—	6	3.1900	4.5000	1.0000

### Compression Type Connector with Insulated Throat - Steel

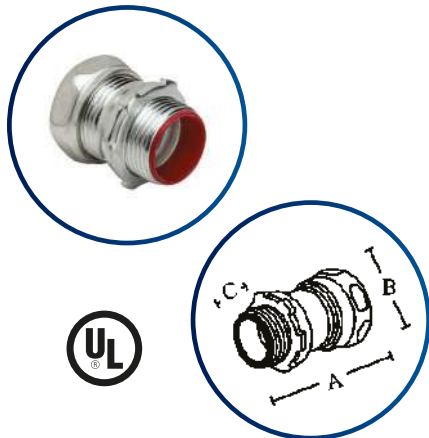

Catalog Number	Size	Unit Carton	Ship Case	Dimensions (in)		
				A	B	C
C-CCNI050	1/2"	25	250	1.4567	0.7087	0.4567
C-CCNI075	3/4"	25	250	1.4843	0.9252	0.4567
C-CCNI100	1"	10	100	1.6535	1.1811	0.6024
C-CCNI125	1 1/4"	—	25	1.4961	1.5118	0.6850
C-CCNI150	1 1/2"	—	20	2.4409	1.7559	0.7323
C-CCNI200	2"	—	15	2.3622	2.2047	0.7323
C-CCNI250	2 1/2"	—	12	2.3800	2.8800	0.8800
C-CCNI300	3"	—	12	2.8800	3.5200	0.8800
C-CCNI350	3 1/2"	—	6	3.0000	4.0000	1.0000
C-CCNI400	4"	—	6	3.1900	4.5000	1.0000

### Compression Type Coupling - Steel

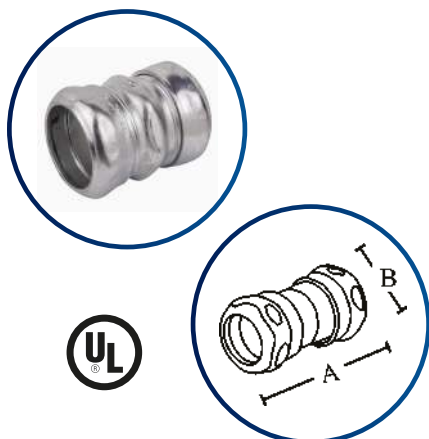

Catalog Number	Size	Unit Carton	Ship Case	Dimensions (in)	
				A	B
C-CCP050	1/2"	25	250	1.6378	0.7087
C-CCP075	3/4"	25	250	1.6378	0.9252
C-CCP100	1"	10	100	1.7323	1.1811
C-CCP025	1 1/4"	—	25	2.4409	1.5118
C-CCP150	1 1/2"	—	20	2.5748	1.7559
C-CCP200	2"	—	15	2.6969	2.2047
C-CCP250	2 1/2"	—	6	3.8750	2.8750
C-CCP300	3"	—	6	4.0000	3.5000
C-CCP350	3 1/2"	—	6	4.4500	4.0000
C-CCP400	4"	—	3	4.9300	4.5000

**EMT 90° Pull Elbows**

Threaded Set Screw Type - EMT to Box  
Zinc Die Cast

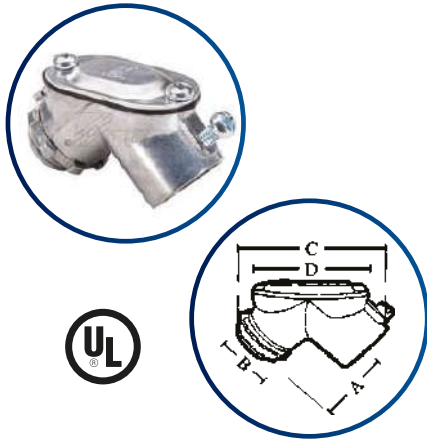

**Features:**

- EMT to box pull elbows
- Removable cover facilitates wire pulling
- Neoprene gasket

**Applications:**

- Indoor or outdoor use
- Use to connect a run of EMT conduit to an outlet box or other material enclosure
- Can be used with EMT indoors only

**Standard Material**

- Zinc die cast

Catalog Number	Size	Unit Carton	Ship Case	A	Dimensions (in)		
					B	C	D
PE-EB050	1/2"	10	100	1.310	1.090	2.400	1.800
PE-EB075	3/4"	5	50	1.470	1.290	2.660	2.140
PE-EB100	1"	—	25	2.800	1.600	3.660	3.160
PE-EB125	1 1/4"	—	20	3.130	1.960	5.160	3.240

**Set Screw Type - EMT to EMT - Zinc Die Cast**

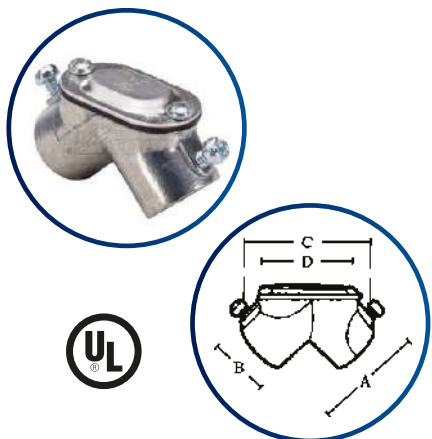

**Features:**

- Corrosion resistant fabrication
- Removable cover facilitates wire pulling
- EMT to EMT pull elbows
- Neoprene gasket

**Applications:**

- Dry location use
- Use to connect EMT conduit together on a 90° bend
- Use a wire pulling elbow to facilitate wire pulling through a sharp bend in a run of EMT conduit

**Standard Material**

- Zinc die cast

Catalog Number	Size	Unit Carton	Ship Case	A	Dimensions (in)		
					B	C	D
PE-EE050	1/2"	10	100	1.310	0.940	2.500	1.780
PE-EE075	3/4"	5	50	1.590	1.240	2.760	2.130
PE-EE100	1"	—	25	1.940	1.610	3.860	3.170
PE-EE125	1 1/4"	—	20	2.260	2.000	4.560	3.250

### EMT Offset Connectors

Set Screw Type - EMT to Box - Zinc Die Cast

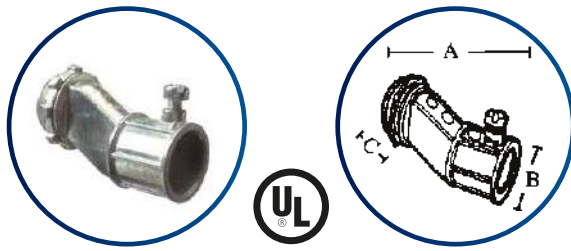

- Features:**
- Concrete tight when taped
- Applications:**
- Indoor or outdoor use
  - Use to connect EMT conduit to a metal outlet box or enclosure where an offset is desired
- Standard Material**
- Zinc die cast

Catalog Number	Size	Unit Carton	Ship Case	Dimensions (in)		
				A	B	C
SOC-EB050	1/2"	10	100	2.100	0.940	0.520
SOC-EB075	3/4"	10	100	3.000	1.160	0.520
SOC-EB100	1"	10	100	3.160	1.420	0.670

Compression Type - EMT to Box - Zinc Die Cast

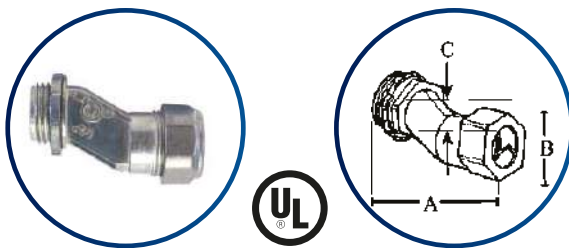

- Features:**
- Concrete tight when taped
- Applications:**
- Indoor or outdoor use
  - Use to connect EMT conduit to a metal outlet box or enclosure where an offset is desired
- Standard Material**
- Zinc die cast

Catalog Number	Size	Unit Carton	Ship Case	Dimensions (in)		
				A	B	C
COC-EB050	1/2"	20	200	2.130	1.000	0.520
COC-EB075	3/4"	10	100	2.900	1.190	0.750
COC-EB100	1"	10	100	3.200	1.420	0.750

Set Screw Type - EMT to EMT - Inside Corner - Zinc Die Cast

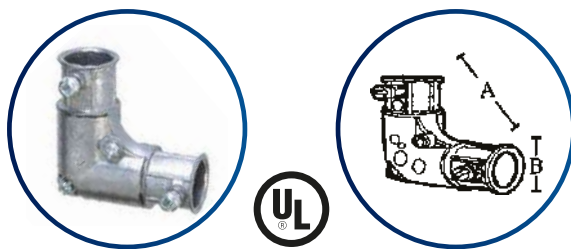

- Features:**
- Set screw assembly provides concrete tight connections when taped
  - Removable cover facilitates wire pulling
- Applications:**
- Dry location use
  - Use to connect EMT conduit together on a 90 degree inside corner
- Standard Material**
- Zinc die cast

Catalog Number	Size	Unit Carton	Ship Case	Dimensions (in)	
				A	B
CZ-CP9050	1/2"	10	100	1.810	1.000
CZ-CP9075	3/4"	5	50	2.000	1.250
CZ-CP9100	1"	5	50	2.200	1.470

**EMT Straps**

**Snap-On Type - One Hole - Steel**

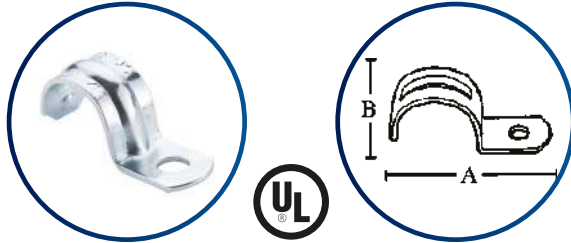

**Features:**

- Snap-on type EMT strap with one hole
- Inverted rib for strength

**Applications:**

- Support EMT conduit

**Standard Material**

- Steel

**Standard Finish**

- Zinc plated

Catalog Number	Size	Unit Carton	Ship Case	Dimensions (in)	
				A	B
CS-ES1050	1/2"	100	1000	1.640	0.790
CS-ES1075	3/4"	100	1000	1.820	0.940
CS-ES1100	1"	50	500	2.180	1.260
CS-ES1125	1 1/4"	25	250	2.830	1.540
CS-ES1150	1 1/2"	10	100	2.950	1.730
CS-ES1200	2"	10	100	3.870	2.050
CS-ES1250	2 1/2"	—	50	5.000	1.280
CS-ES1300	3"	—	25	5.550	1.280
CS-ES1350	3 1/2"	—	25	6.370	1.280
CS-ES1400	4"	—	25	6.870	1.280

**Snap-On Type - Two Hole - Steel**

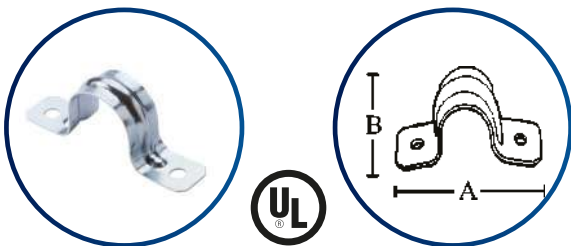

**Features:**

- Snap-on type EMT strap with two hole

**Applications:**

- Use to support EMT conduit where greater load bearing is required

**Standard Material**

- Steel

**Standard Finish**

- Zinc plated

Catalog Number	Size	Unit Carton	Ship Case	Dimensions (in)	
				A	B
CS-ES2050	1/2"	50	500	2.170	0.750
CS-ES2075	3/4"	50	500	2.720	0.940
CS-ES2100	1"	50	500	2.930	1.220
CS-ES2125	1 1/4"	20	200	3.620	1.570
CS-ES2150	1 1/2"	20	200	4.210	1.850
CS-ES2200	2"	—	50	4.600	2.240
CS-ES2250	2 1/2"	—	25	5.910	1.000
CS-ES2300	3"	—	25	6.710	1.000
CS-ES2350	3 1/2"	—	25	7.510	1.000
CS-ES2400	4"	—	25	8.310	1.000

**EMT Elbows**

90° - Galvanized Steel

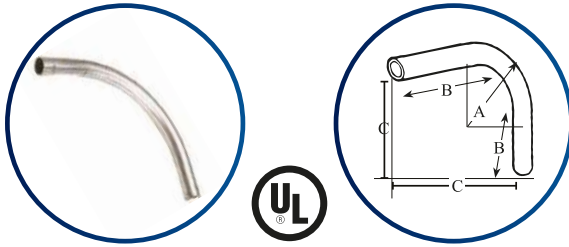

**Features:**

- Low conductivity, high corrosion resistance
- Smooth defect free interior and exterior

**Applications:**

- For a secure connection to EMT conduit; bend enables directional changes in conduit

**Standard Material**

- Galvanized steel

Catalog Number	Size	Ship Case	A Min. UL Radius	B Straight Leg Each End	C Offset
EL9050	1/2"	50	4.000	2.875	6.343
EL9075	3/4"	50	4.500	2.875	6.781
EL9100	1"	20	5.750	3.000	8.901
EL9125	1 1/4"	20	7.250	3.250	10.250
EL9150	1 1/2"	10	8.250	3.625	11.937
EL9200	2"	10	9.500	4.187	14.031
EL9250	2 1/2"	1	10.500	5.250	16.000
EL9300	3"	1	13.000	5.812	18.947
EL9350	3 1/2"	1	15.000	6.750	22.218
EL9400	4"	1	16.000	6.937	23.437

**EMT Elbows**

45° - Galvanized Steel

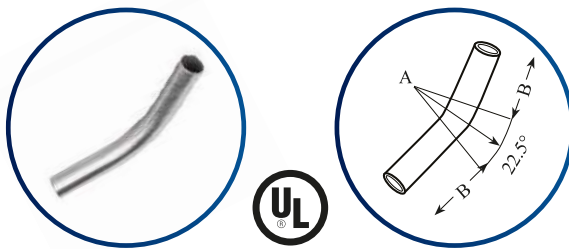

**Features:**

- Low conductivity, high corrosion resistance
- Smooth defect free interior and exterior

**Applications:**

- For a secure connection to EMT conduit; bend enables directional changes in conduit

**Standard Material**

- Galvanized steel

Catalog Number	Size	Ship Case	A Min. UL Radius	B Straight Leg Each End
EL4050	1/2"	50	4.000	2.875
EL4075	3/4"	50	4.500	2.875
EL4100	1"	35	5.750	3.000
EL4125	1 1/4"	30	7.250	3.250
EL4150	1 1/2"	15	8.250	3.625
EL4200	2"	15	9.500	4.187
EL4250	2 1/2"	1	10.500	5.250
EL4300	3"	1	13.000	5.812
EL4350	3 1/2"	1	15.000	6.750
EL4400	4"	1	16.000	6.937



ITCC



**IMC/RMC FITTINGS  
& ELBOWS**

### Rigid Connectors

Compression Type - Steel

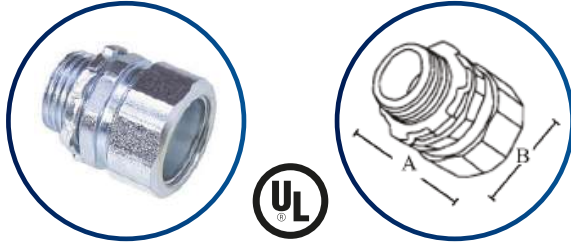

**Features:**

- Concrete tight when taped
- Threadless

**Applications:**

- Use to join unthreaded Rigid or IMC conduit to steel outlet box or metal enclosure

**Standard Material**

- Steel

**Standard Finish**

- Zinc plated

Catalog Number	Size	Unit Carton	Ship Case	Dimensions (in)	
				A	B
R-CCN050	1/2"	20	200	1.398	0.886
R-CCN075	3/4"	10	100	1.496	1.063
R-CCN100	1"	5	50	1.720	1.378
R-CCN125	1 1/4"	5	50	1.890	1.700
R-CCN150	1 1/2"	—	12	2.126	1.992
R-CCN200	2"	—	12	2.056	2.429
R-CCN250	2 1/2"	—	5	3.000	3.750
R-CCN300	3"	—	3	3.125	4.250
R-CCN350	3 1/2"	—	2	3.187	4.750
R-CCN400	4"	—	2	3.437	5.312

### Rigid Couplings

Compression Type - Steel

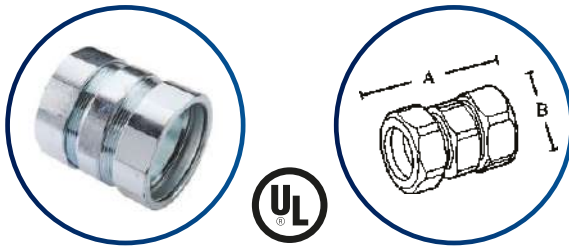

**Features:**

- Compression type
- Concrete tight
- Threadless

**Applications:**

- Use to join two lengths unthreaded Rigid or IMC conduit to steel outlet box or metal enclosure

**Standard Material**

- Steel

**Standard Finish**

- Zinc plated

Catalog Number	Size	Unit Carton	Ship Case	Dimensions (in)	
				A	B
R-CCP050	1/2"	10	100	1.799	0.875
R-CCP075	3/4"	10	100	2.055	1.086
R-CCP100	1"	5	50	2.087	1.338
R-CCP125	1 1/4"	5	50	2.512	1.732
R-CCP150	1 1/2"	—	12	2.563	1.990
R-CCP200	2"	—	5	2.350	2.422
R-CCP250	2 1/2"	—	5	5.750	3.930
R-CCP300	3"	—	3	5.720	4.660
R-CCP350	3 1/2"	—	2	6.000	5.200
R-CCP400	4"	—	2	6.810	5.750

\*Malleable iron materials are also available. Please add 'M' to the Part Number while ordering \*R-CCN075M, R-CCP075M, etc.

## Rigid Connectors

Set Screw Type - Steel

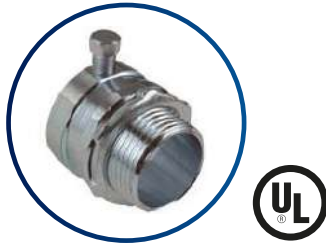

**Features:**

- Concrete tight when taped
- Threadless

**Applications:**

- Use to join unthreaded Rigid or IMC conduit to steel outlet box or metal enclosure

**Standard Material**

- Steel

**Standard Finish**

- Zinc plated

Catalog Number	Size	Unit Carton	Ship Case	Dimensions (in)	
				A	B
C-RCN050	1/2"	20	200	1.398	0.886
C-RCN075	3/4"	10	100	1.496	1.063
C-RCN100	1"	5	50	1.720	1.378
C-RCN125	1 1/4"	5	50	1.890	1.700
C-RCN150	1 1/2"	—	12	2.126	1.992
C-RCN200	2"	—	12	2.056	2.429
C-RCN250	2 1/2"	—	5	3.000	3.750
C-RCN300	3"	—	3	3.125	4.250
C-RCN350	3 1/2"	—	2	3.187	4.750
C-RCN400	4"	—	2	3.437	5.312

## Rigid Couplings

Set Screw Type - Steel

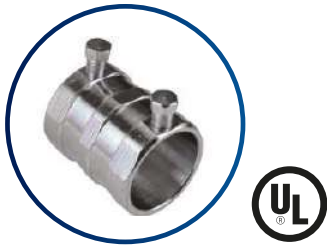

**Features:**

- Compression type
- Concrete tight
- Threadless

**Applications:**

- Use to join two lengths unthreaded Rigid or IMC conduit to steel outlet box or metal enclosure

**Standard Material**

- Steel

**Standard Finish**

- Zinc plated

Catalog Number	Size	Unit Carton	Ship Case	Dimensions (in)	
				A	B
C-RCP050	1/2"	10	100	1.799	0.875
C-RCP075	3/4"	10	100	2.055	1.086
C-RCP100	1"	5	50	2.087	1.338
C-RCP125	1 1/4"	5	50	2.512	1.732
C-RCP150	1 1/2"	—	12	2.563	1.990
C-RCP200	2"	—	5	2.350	2.422
C-RCP250	2 1/2"	—	5	5.750	3.930
C-RCP300	3"	—	3	5.720	4.660
C-RCP350	3 1/2"	—	2	6.000	5.200
C-RCP400	4"	—	2	6.810	5.750

\*Malleable iron materials are also available. Please add 'M' to the Part Number while ordering "R-CCN075M, R-CCP075M, etc.

### Pull Elbows with Gasket

Rigid to Rigid

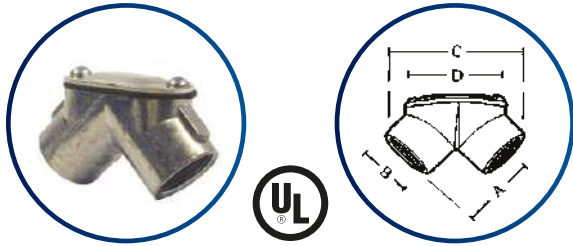

**Features:**

- Low conductivity, high corrosion resistance
- Smooth defect free interior and exterior

**Applications:**

- For a secure connection to EMT conduit; bend enables directional changes in conduit

**Standard Material**

- Galvanized steel

Catalog Number	Size	Unit Carton	Ship Case	Dimensions (in)			
				A	B	C	D
PE-RR050	1/2"	10	100	1.310	1.090	2.500	1.780
PE-RR075	3/4"	5	50	1.430	1.290	2.760	2.130
PE-RR100	1"	—	25	1.950	1.590	3.860	3.170
PE-RR125	1 1/4"	—	20	2.260	1.970	4.560	3.250

### Pull Elbows with Gasket

Rigid to Box

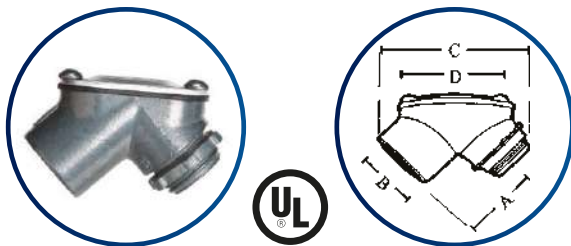

**Features:**

- Rigid to Rigid
- Removable cover facilitates wire pulling
- Neoprene gasket

**Applications:**

- Indoor or outdoor use (Rigid only)
- Use a wire pulling elbow to facilitate wire pulling through a sharp bend in a run of threaded Rigid or IMC conduit
- Can be used with EMT indoors only

**Standard Material**

- Zinc die cast
- Neoprene gasket

Catalog Number	Size	Unit Carton	Ship Case	Dimensions (in)			
				A	B	C	D
PE-RB050	1/2"	10	100	1.310	1.090	2.400	1.800
PE-RB075	3/4"	5	50	1.470	1.290	2.660	2.140
PE-RB100	1"	—	25	2.800	1.600	3.660	3.160
PE-RB125	1 1/4"	—	20	3.130	1.960	5.160	3.240

## Rigid Couplings

Three Piece Type  
Zinc Die Cast / Malleable Iron / Steel

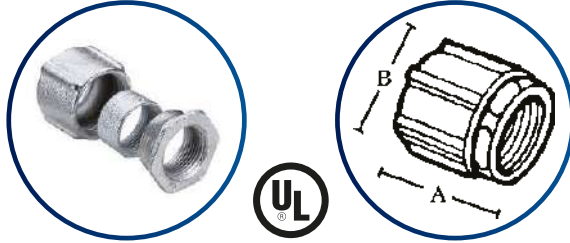

**Features:**

- For threaded Rigid or IMC conduit

**Applications:**

- Use as a threaded coupling between lengths of threaded Rigid or IMC conduit

**Standard Material**

- Malleable iron / Zinc die cast / Steel

**Standard Finish**

- Zinc plated

Catalog Number	Size	Unit Carton	Ship Case	Dimensions (in)	
				A	B
C-TPC050	1/2"	20	200	1.430	1.360
C-TPC075	3/4"	10	100	1.630	1.580
C-TPC100	1"	5	50	1.810	1.890
C-TPC125	1 1/4"	5	50	2.190	2.380
C-TPC150	1 1/2"	3	30	2.310	2.830
C-TPC200	2"	—	20	2.440	3.290

## Offset Nipples

3/4" Offset  
Zinc Die Cast

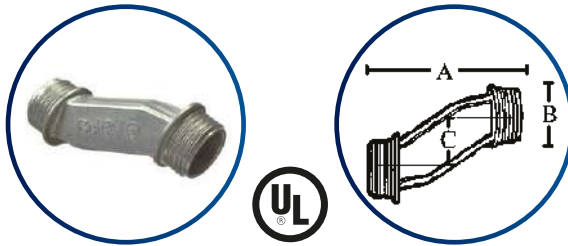

**Features:**

- Enables easier direction change of conduit

**Applications:**

- Indoor or outdoor use
- Use as an offset connector between two enclosures
- Offsets the axis of the raceways by 3/4"

**Standard Material**

- Zinc die cast

Catalog Number	Size	Unit Carton	Ship Case	Dimensions (in)		
				A	B	C
R-ON050	1/2"	10	100	2.460	1.000	0.750
R-ON075	3/4"	10	100	2.560	1.220	0.750
R-ON100	1"	10	100	2.560	1.525	0.750
R-ON125	1 1/4"	5	50	2.910	1.910	0.750
R-ON150	1 1/2"	5	50	3.080	2.125	0.750
R-ON200	2"	2	20	3.145	2.665	0.750
R-ON250	2 1/2"	—	2	3.970	3.280	0.750
R-ON300	3"	—	2	4.420	3.795	0.750

## Watertight Conduit Hubs

Insulated Throat - Zinc Die Cast

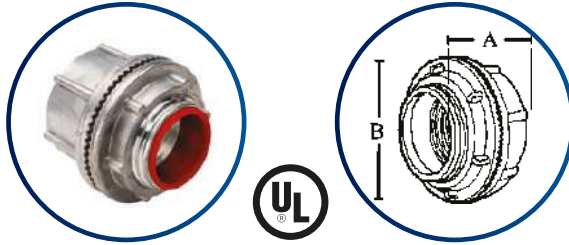

**Features:**

- Flame-retardant insulated throat
- Rain, oil, and dust tight
- Oversized locknut prevents damage from vibrations and promotes positive grounding

**Applications:**

- Indoor or outdoor
- Use to connect Rigid or IMC conduit to a load center or other metal enclosure where a watertight joint is required at knockouts or slip-fit holes

**Standard Material**

- Zinc die cast

Catalog Number	Size	Unit Carton	Ship Case	Dimensions (in)	
				A	B
R-WH050	1/2"	25	250	1.299	1.339
R-WH075	3/4"	10	100	1.496	1.634
R-WH100	1"	10	100	1.654	1.890
R-WH125	1 1/4"	2	20	1.811	2.303
R-WH150	1 1/2"	2	20	1.772	2.559
R-WH200	2"	2	10	1.909	3.150
R-WH250	2 1/2"	—	5	2.126	3.858
R-WH300	3"	—	5	2.579	4.291
R-WH350	3 1/2"	—	5	2.440	4.880
R-WH400	4"	—	1	2.677	5.394

## With Bonding Screw - Zinc Die Cast

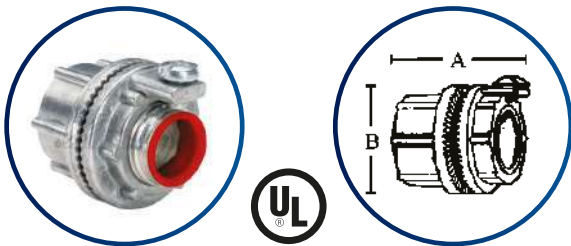

**Features:**

- Flame-retardant insulated throat
- Rain, oil, and dust tight
- Oversized locknut prevents damage from vibrations and promotes positive grounding

**Applications:**

- Indoor or outdoor
- Use to connect Rigid or IMC conduit to a load center or other metal enclosure where a watertight joint is required at knockouts or slip-fit holes

**Standard Material**

- Zinc die cast

Catalog Number	Size	Unit Carton	Ship Case	Dimensions (in)	
				A	B
R-WH050B	1/2"	25	250	1.299	1.339
R-WH075B	3/4"	10	100	1.496	1.634
R-WH100B	1"	10	100	1.654	1.890
R-WH125B	1 1/4"	2	20	1.811	2.303
R-WH150B	1 1/2"	2	20	1.772	2.559
R-WH200B	2"	2	20	1.909	3.150
R-WH250B	2 1/2"	—	2	2.126	3.858
R-WH300B	3"	—	2	2.579	4.291
R-WH350B	3 1/2"	—	1	2.440	4.880
R-WH400B	4"	—	1	2.677	5.394

\*Malleable iron materials are also available. Please add 'M' to the Part Number while ordering "R-WH075M, R-WH075BM, etc.

**Rigid Straps**

**Snap-On Type One Hole - Steel**

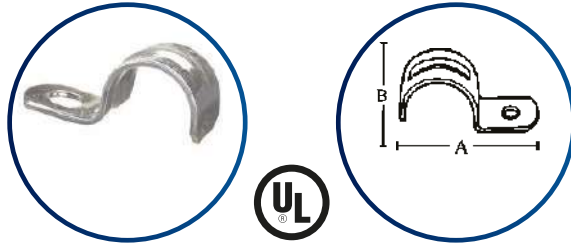

**Features:**

- Inverted rib for strength
- Easy to install

**Applications:**

- Indoor or outdoor use
- Use to secure Rigid or IMC conduit to wood, masonry or where greater load bearing is required

**Standard Material**

- Steel

Catalog Number	Size	Unit Carton	Ship Case	Dimensions (in)	
				A	B
C-RS1050	1/2"	50	500	1.910	0.870
C-RS1075	3/4"	50	500	2.260	1.060
C-RS1100	1"	25	250	2.560	1.300
C-RS1125	1 1/4"	20	200	2.790	1.730
C-RS1150	1 1/2"	20	200	3.690	1.970
C-RS1200	2"	10	100	4.170	2.280
C-RS1250	2 1/2"	—	50	4.970	2.910
C-RS1300	3"	—	25	5.650	3.350
C-RS1350	3 1/2"	—	25	6.300	4.130
C-RS1400	4"	—	25	6.890	4.370
C-RS1500	5"	—	10	9.000	1.500
C-RS1600	6"	—	10	10.350	1.500

**Snap-On Type Two Hole - Steel**

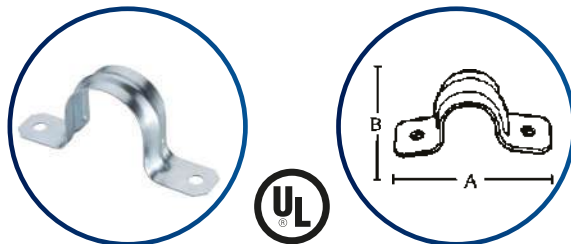

**Features:**

- Greater load bearing capability
- Easy to install

**Applications:**

- Indoor or outdoor use
- Use to secure Rigid or IMC conduit to wood, masonry or where greater load bearing is required

**Standard Material**

- Steel

Catalog Number	Size	Unit Carton	Ship Case	Dimensions (in)	
				A	B
C-RS2050	1/2"	50	500	2.520	0.870
C-RS2075	3/4"	50	500	2.910	1.060
C-RS2100	1"	25	250	3.230	1.300
C-RS2125	1 1/4"	20	200	4.410	1.750
C-RS2150	1 1/2"	10	100	4.490	1.970
C-RS2200	2"	—	50	5.200	2.280
C-RS2250	2 1/2"	—	25	6.060	2.910
C-RS2300	3"	—	25	6.750	3.580
C-RS2350	3 1/2"	—	25	7.480	4.060
C-RS2400	4"	—	25	8.270	4.570
C-RS2500	5"	—	10	10.600	1.250
C-RS2600	6"	—	10	11.850	1.250

**Rigid Straps**

Snap-On Type - One Hole  
Malleable Iron



**Features:**

- Inverted rib for strength

**Applications:**

- Indoor or outdoor use
- Use to secure Rigid or IMC conduit to wood, masonry or similar surfaces
- To be used with clamp back

**Standard Material**

- Malleable iron

**Standard Finish**

- Zinc plated

Catalog Number	Size	Unit Carton	Ship Case	Dimensions		
				A	B	C
RSMI050	1/2"	100	1000	2.250	0.660	0.940
RSMI075	3/4"	50	500	2.560	0.750	1.120
RSMI100	1"	25	250	3.060	0.810	1.500
RSMI125	1 1/4"	20	200	3.690	0.880	1.880
RSMI150	1 1/2"	10	100	4.000	1.000	2.060
RSMI200	2"	—	25	5.060	1.130	2.560
RSMI250	2 1/2"	—	25	5.940	1.380	3.060
RSMI300	3"	—	25	7.440	1.630	3.810
RSMI350	3 1/2"	—	10	8.190	1.810	4.380
RSMI400	4"	—	10	8.690	2.000	5.000
RSMI500	5"	—	10	9.375	2.687	6.000
RSMI600	6"	—	10	1.0375	3.125	7.000

\*Back Spacers are also available. Please add "BS" to the Part Number while ordering "RSMI075BS"

**Male Bushing**

Zinc Die Cast / Malleable Iron

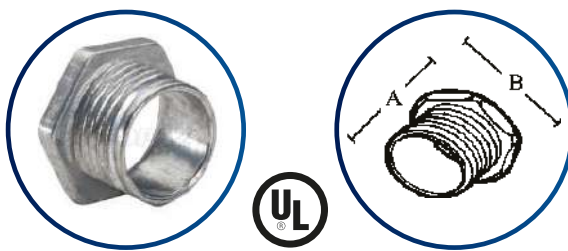

**Features:**

- Threaded NPSM for Rigid conduit and IMC
- Use with loxknuts

**Applications:**

- Serves as a short raceway between enclosures

**Standard Material**

- Die cast zinc / Malleable iron

Catalog Number	Size	Unit Carton	Ship Case	Dimensions	
				A	B
RMB050	1/2"	100	1000	0.680	1.020
RMB075	3/4"	50	500	0.750	1.290
RMB100	1"	25	250	0.870	1.530
RMB125	1 1/4"	25	200	0.940	1.890
RMB150	1 1/2"	25	250	0.910	2.300
RMB200	2"	10	40	1.070	2.880
RMB250	2 1/2"	10	40	1.380	3.390
RMB300	3"	10	40	1.440	4.060
RMB350	3 1/2"	10	40	1.470	4.610
RMB400	4"	5	20	1.470	5.150

\*For Malleable materials, please add "M" to the Part Number while ordering "RSM075M"



## Conduit Bushing

Non-insulated / Zinc Die Cast

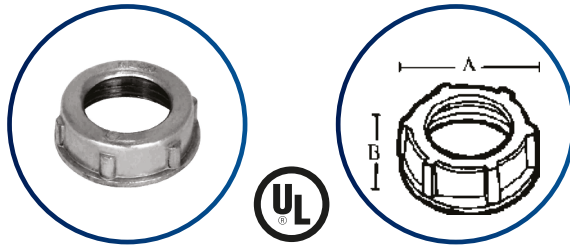

**Features:**

- Rounded surface of the bushing prevents damage to wire insulation

**Applications:**

- Indoor or outdoor use
- Use with locknut to terminate threaded Rigid or IMC conduit to an outlet box

**Standard Material**

- Zinc die cast

Catalog Number	Size	Unit Carton	Ship Case	Dimensions	
				A	B
RBNI050	1/2"	100	1000	0.950	0.350
RBNI075	3/4"	100	1000	1.100	0.390
RBNI100	1"	50	500	1.460	0.430
RBNI125	1 1/4"	25	250	1.840	0.470
RBNI150	1 1/2"	25	250	2.090	0.510
RBNI200	2"	25	100	2.570	0.550
RBNI250	2 1/2"	10	100	3.130	0.630
RBNI300	3"	—	10	3.770	0.790
RBNI350	3 1/2"	—	10	4.359	0.850
RBNI400	4"	—	10	4.800	0.810
RBNI500	5"	—	5	6.150	1.300
RBNI600	6"	—	5	7.250	1.300

## Rigid Bushing

Insulated - 105° C Thermoplastic Liner - Zinc Die Cast

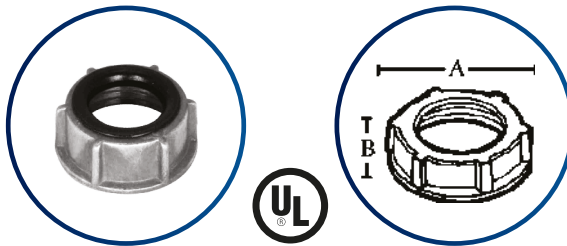

**Features:**

- Liner is rated flame retardant to 105° C

**Applications:**

- Indoor or outdoor use
- Use with locknut to terminate Rigid or IMC conduit to an outlet box
- Plastic liner prevents damage to wire insulation

**Standard Material**

- Malleable iron

**Standard Finish**

- Zinc die cast
- Plastic insulator

Catalog Number	Size	Unit Carton	Ship Case	Dimensions	
				A	B
C-RBI050	1/2"	100	1000	0.950	0.350
C-RBI075	3/4"	50	500	1.100	0.390
C-RBI100	1"	50	500	1.460	0.430
C-RBI125	1 1/4"	25	250	1.840	0.470
C-RBI150	1 1/2"	25	250	2.090	0.510
C-RBI200	2"	—	100	2.570	0.550
C-RBI250	2 1/2"	—	50	3.130	0.630
C-RBI300	3"	—	25	3.770	0.790
C-RBI350	3 1/2"	—	25	4.359	0.866
C-RBI400	4"	—	10	4.800	0.810
C-RBI500	5"	—	5	6.150	1.300
C-RBI600	6"	—	5	7.250	1.125

\*Malleable iron materials are also available. Please add "M" to the Part Number while ordering "RBNI075M"

### Insulated Grounding Bushing with Aluminium Lay-In Lug

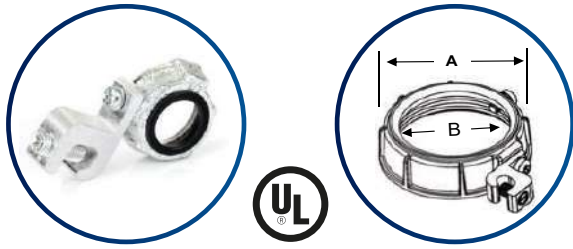

**Features:**

- Use to provide a means of grounding Rigid or IMC conduit
- Use with locknut to terminate service conduit to a cabinet
- Lug provided for bonding jumper to a neutral bus bar
- Round surface of bushing prevents damage to wire insulation
- Plastic liner prevents damage to wire insulation

**Standard Material**

- Body-Malleable iron
- Plastic insulator
- Lug-Aluminium
- Clamping screw-steel
- Set screw-steel

Catalog Number	Size	Grounding Lug Min.	Wire Size Max.	Unit Carton	Ship Case	Dimensions	
						A	B
RBIG050	1/2"	14	4	50	500	0.830	0.550
RBIG075	3/4"	14	4	50	500	1.260	0.710
RBIG100	1"	14	4	25	250	1.580	0.980
RBIG125	1 1/4"	14	4	20	200	1.980	1.290
RBIG150	1 1/2"	14	4	10	100	2.150	1.480
RBIG200	2"	14	4	10	100	2.650	1.810
RBIG250	2 1/2"	14	1/0	—	50	3.190	2.240
RBIG300	3"	14	1/0	—	50	3.820	2.840
RBIG400	4"	14	1/0	—	10	4.800	3.820

### Reducing Bushings

Steel / Zinc Die Cast

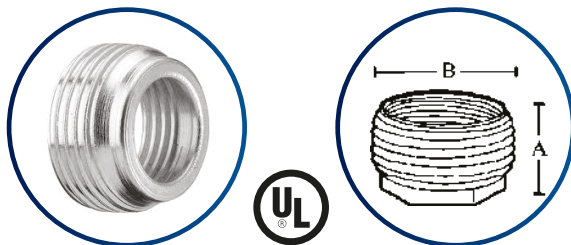

**Features:**

- Rounded bushing protects conductor

**Applications:**

- Dry location use only
- Use to reduce the entry size of a run of threaded conduit

**Standard Material**

- Steel
- Standard Finish
- Zinc plated

Catalog Number	Size	Ship Case	Dimensions	
			A	B
C-RB075A	3/4" x 1/2"	100	0.650	0.920
C-RB100A	1" x 1/2"	50	0.715	1.125
C-RB100B	1" x 3/4"	50	0.715	1.125
C-RB125A	1-1/4" x 1/2"	25	0.820	1.470
C-RB125B	1-1/4" x 3/4"	25	0.820	1.470
C-RB125C	1-1/4" x 1"	25	0.820	1.470
C-RB150A	1-1/2" x 1/2"	25	0.850	1.700
C-RB150B	1-1/2" x 3/4"	25	0.850	1.700
C-RB150C	1-1/2" x 1"	25	0.850	1.700
C-RB150D	1-1/2" x 1-1/4"	25	0.850	1.700
C-RB200A	2" x 1/2"	10	0.970	2.230
C-RB200B	2" x 3/4"	10	0.970	2.230
C-RB200C	2" x 1"	10	0.970	2.230
C-RB200D	2" x 1-1/4"	10	0.970	2.230
C-RB200E	2" x 1-1/2"	10	0.970	2.230

**Rigid Elbows**

90° - Galvanized Steel

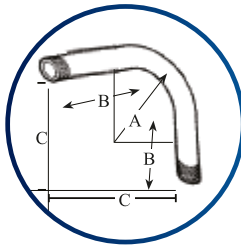

**Features:**

- Low conductivity, high corrosion resistance
- Smooth defect free interior and exterior

**Applications:**

- For a secure connection to Rigid conduit; bend enables directional changes in conduit

**Standard Material**

- Galvanized steel

Catalog Number	Size	Ship Case	(A) Min. UL Radius	(B) Straight Leg Each End	(C) Offset
RL9050	1/2"	50	4.000	2.875	6.343
RL9075	3/4"	50	4.500	2.875	6.781
RL9100	1"	20	5.750	3.000	8.901
RL9125	1 1/4"	20	7.250	3.250	10.250
RL9150	1 1/2"	10	8.250	3.625	11.937
RL9200	2"	10	9.500	4.187	14.031
RL9250	2 1/2"	1	10.50	5.250	16.000
RL9300	3"	1	13.00	5.812	18.947
RL9350	3 1/2"	1	15.00	6.750	22.218
RL9400	4"	1	16.00	6.937	23.437
RL9500	5"	1	25.00	11.120	36.156
RL9600	6"	1	30.00	12.437	41.460

**Rigid Elbows**

45° - Galvanized Steel

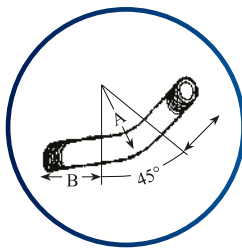

**Features:**

- Low conductivity, high corrosion resistance
- Smooth defect free interior and exterior

**Applications:**

- For a secure connection to Rigid conduit; bend enables directional changes in conduit

**Standard Material**

- Galvanized steel

Catalog Number	Size	Ship Case	(A) Min. UL Radius	(B) Straight Leg Each End
RL4050	1/2"	50	4.000	2.875
RL4075	3/4"	50	4.500	2.875
RL4100	1"	35	5.750	3.000
RL4125	1 1/4"	30	7.250	3.250
RL4150	1 1/2"	15	8.250	3.625
RL4200	2"	15	9.500	4.187
RL4250	2 1/2"	1	10.50	5.250
RL4300	3"	1	13.00	5.812
RL4350	3 1/2"	1	15.00	6.750
RL4400	4"	1	16.00	6.937
RL4500	5"	1	25.00	8.125
RL4600	6"	1	30.00	13.250

## Conduit Nipples

Galvanized Steel



**Features:**

- NPT thread
- High corrosion resistance

**Applications:**

- Use to extend a length of threaded Rigid or IMC conduit

**Standard Material**

- Galvanized steel

## Rigid Closed Nipples

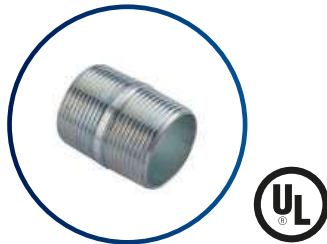

Catalog Number	Size	Ship Case
CNP050	1/2"	25
CNP075	3/4"	25
CNP100	1"	25
CNP125	1 1/4"	25
CNP150	1 1/2"	25
CNP200	2"	25
CNP250	2 1/2"	1
CNP300	3"	1
CNP350	3 1/2"	1
CNP400	4"	1
CNP500	5"	1
CNP600	6"	1

### C-RNP050

Catalog Number	Size	Lenght Inches	Ship Case
C-RNP050112	1/2"	1-1/2"	25
C-RNP050200	1/2"	2	25
C-RNP050212	1/2"	2-1/2"	25
C-RNP050300	1/2"	3	25
C-RNP050312	1/2"	3-1/2"	25
C-RNP050400	1/2"	4	25
C-RNP050500	1/2"	5	25
C-RNP050600	1/2"	6	25
C-RNP050800	1/2"	8	1
C-RNP0501000	1/2"	10	1
C-RNP0501200	1/2"	12	1

### C-RNP075

Catalog Number	Size	Lenght Inches	Ship Case
C-RNP075112	3/4"	1-1/2"	25
C-RNP075200	3/4"	2	25
C-RNP075212	3/4"	2-1/2"	25
C-RNP075300	3/4"	3	25
C-RNP075312	3/4"	3-1/2"	25
C-RNP075400	3/4"	4	25
C-RNP075500	3/4"	5	25
C-RNP075600	3/4"	6	25
C-RNP075800	3/4"	8	1
C-RNP0751000	3/4"	10	1
C-RNP0751200	3/4"	12	1

### C-RNP100

Catalog Number	Size	Lenght Inches	Ship Case
C-RNP100112	1"	1-1/2"	25
C-RNP100200	1"	2	25
C-RNP100212	1"	2-1/2"	25
C-RNP100300	1"	3	25
C-RNP100312	1"	3-1/2"	25
C-RNP100400	1"	4	25
C-RNP100500	1"	5	25
C-RNP100600	1"	6	25
C-RNP100800	1"	8	1
C-RNP1001000	1"	10	1
C-RNP1001200	1"	12	1

Conduit Nipples

Galvanized Steel (continued)



C-RNP125

Catalog Number	Size	Lenght Inches	Ship Case
C-RNP125200	1"-1/4"	2	25
C-RNP125212	1"-1/4"	2-1/2	25
C-RNP125300	1"-1/4"	3	25
C-RNP125312	1"-1/4"	3-1/2	25
C-RNP125400	1"-1/4"	4	25
C-RNP125500	1"-1/4"	5	25
C-RNP125600	1"-1/4"	6	25
C-RNP125800	1"-1/4"	8	1
C-RNP1251000	1"-1/4"	10	1
C-RNP1251200	1"-1/4"	12	1

C-RNP150

Catalog Number	Size	Lenght Inches	Ship Case
C-RNP150200	1"-1/2"	2	25
C-RNP150212	1"-1/2"	2-1/2	25
C-RNP150300	1"-1/2"	3	25
C-RNP150312	1"-1/2"	3-1/2	25
C-RNP150400	1"-1/2"	4	25
C-RNP150500	1"-1/2"	5	25
C-RNP150600	1"-1/2"	6	25
C-RNP150800	1"-1/2"	8	1
C-RNP1501000	1"-1/2"	10	1
C-RNP1501200	1"-1/2"	12	1

C-RNP200

Catalog Number	Size	Lenght Inches	Ship Case
C-RNP200212	2"	2-1/2	25
C-RNP200300	2"	3	25
C-RNP200312	2"	3-1/2	40
C-RNP200400	2"	4	40
C-RNP200500	2"	5	40
C-RNP200600	2"	6	30
C-RNP200800	2"	8	1
C-RNP2001000	2"	10	1
C-RNP2001200	2"	12	1

C-RNP250

Catalog Number	Size	Lenght Inches	Ship Case
C-RNP250300	2"-1/2"	3	1
C-RNP250312	2"-1/2"	3-1/2	1
C-RNP250400	2"-1/2"	4	1
C-RNP250500	2"-1/2"	5	1
C-RNP250600	2"-1/2"	6	1
C-RNP250800	2"-1/2"	8	1
C-RNP2501000	2"-1/2"	10	1
C-RNP2501200	2"-1/2"	12	1

C-RNP300

Catalog Number	Size	Lenght Inches	Ship Case
C-RNP300300	3"	3	1
C-RNP300312	3"	3-1/2	1
C-RNP300400	3"	4	1
C-RNP300500	3"	5	1
C-RNP300600	3"	6	1
C-RNP300800	3"	8	1
C-RNP3001000	3"	10	1
C-RNP3001200	3"	12	1

C-RNP350

Catalog Number	Size	Lenght Inches	Ship Case
C-RNP350400	3"-1/2"	4	1
C-RNP350500	3"-1/2"	5	1
C-RNP350600	3"-1/2"	6	1
C-RNP350800	3"-1/2"	8	1
C-RNP3501000	3"-1/2"	10	1
C-RNP3501200	3"-1/2"	12	1

C-RNP400

Catalog Number	Size	Lenght Inches	Ship Case
C-RNP300400	4"	4	1
C-RNP300500	4"	5	1
C-RNP300600	4"	6	1
C-RNP300800	4"	8	1
C-RNP3001000	4"	10	1
C-RNP3001200	4"	12	1

## Rigid Couplings

Tubular Threaded Type - Galvanized Steel

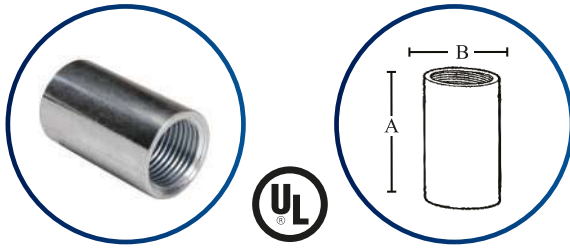

**Features:**

NPSM thread type Applications  
 Indoor or outdoor use  
 Use to join and ensure proper alignment  
 to threaded Rigid or IMC conduit

**Standard Material**

Steel Standard Finish  
 Zinc plated

Catalog Number	Size	Threads Per Inch	Ship Case	Dimensions (in)	
				A	B
C-RCP050	1/2"	14	100	1.570	1.020
C-RCP075	3/4"	14	50	1.650	1.260
C-RCP100	1"	11-1/2	30	1.970	1.540
C-RCP125	1 1/4"	11-1/2	25	2.050	1.890
C-RCP150	1 1/2"	11-1/2	25	2.050	2.170
C-RCP200	2"	11-1/2	20	2.360	2.680
C-RCP250	2 1/2"	8	12	3.150	3.270
C-RCP300	3"	8	8	3.350	3.860
C-RCP350	3 1/2"	8	4	3.540	4.490
C-RCP400	4"	8	4	3.540	4.880
C-RCP500	5"	8	2	3.860	5.980
C-RCP600	6"	8	1	4.250	7.090

## Rigid Locknuts

Zinc Die Cast

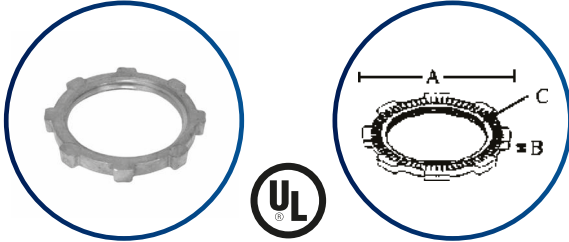

**Features:**

- Tightens without deformation
- Serrated teeth prevent loosening from vibrations

**Applications:**

- Affixes Rigid conduit to an electrical box or other metal enclosure
- To connect externally threaded conduit connector to a threadless opening in a box or enclosure

**Standard Material**

- Zinc die cast

Catalog Number	Size	Threads Per Inch	Unit Carton	Ship Case	Dimensions (in)		Thread Pitch Diameter
					A	B	
LKNZ050	1/2"	14	200	2000	1.120	0.150	0.787-0.797
LKNZ075	3/4"	14	100	1000	1.330	0.150	0.999-1.009
LKNZ100	1"	11-1/2	100	1000	1.680	0.190	1.250-1.260
LKNZ125	1 1/4"	11-1/2	50	500	2.150	0.190	1.595-1.605
LKNZ150	1 1/2"	11-1/2	50	500	2.350	0.190	1.837-1.847
LKNZ200	2"	11-1/2	50	200	2.890	0.190	2.307-2.317
LKNZ250	2 1/2"	8	25	100	3.430	0.250	2.777-2.788
LKNZ300	3"	8	25	100	4.120	0.250	3.403-3.414
LKNZ400	3-1/2"	8	10	40	4.670	0.270	3.892-3.904
LKNZ600	4"	8	10	40	5.250	0.270	4.399-4.411

## Rigid Locknuts

Steel

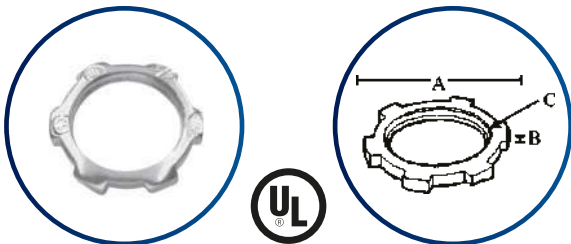

**Features:**

- Tightens without deformation

**Applications:**

- To connect externally threaded conduit connector to threadless opening in a box or enclosure

**Standard Material**

- Steel

**Standard Finish**

- Zinc plated

Catalog Number	Size	Threads Per Inch	Unit Carton	Ship Case	Dimensions (in)		Thread Pitch Diameter
					A	B	
C-LKN050	1/2"	14	100	2000	1.150	0.110	0.787-0.797
C-LKN075	3/4"	14	100	1000	1.450	0.115	0.999-1.009
C-LKN100	1"	11-1/2	100	1000	1.750	0.140	1.250-1.260
C-LKN125	1 1/4"	11-1/2	50	500	2.100	0.140	1.595-1.605
C-LKN150	1 1/2"	11-1/2	50	500	2.400	0.140	1.837-1.847
C-LKN200	2"	11-1/2	25	250	2.950	0.140	2.307-2.317
C-LKN250	2 1/2"	8	—	50	3.550	0.185	2.777-2.788
C-LKN300	3"	8	—	50	3.550	0.190	3.403-3.414
C-LKN350	3-1/2"	8	—	25	4.200	0.190	3.892-3.904
C-LKN400	4"	8	—	25	4.750	0.190	4.399-4.411
C-LKN500	5"	8	—	10	6.670	0.380	5.488-5.500
C-LKN600	6"	8	—	10	7.930	0.400	6.545-6.557

## Liquid Tight Locknuts

Steel

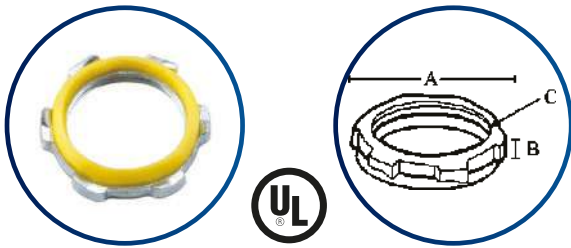

**Features:**

- Zinc plated with PVC molded gasket for a watertight seal

**Applications:**

- Indoor or outdoor use
- Use to secure Rigid or IMC conduit or various threaded fittings to a steel outlet box or other metal enclosures, when moisture proof protection is required

**Standard Material**

- Steel

**Standard Finish**

- Zinc plated
- PVC gasket

Catalog Number	Size	Threads Per Inch	Unit Carton	Ship Case	Dimensions (in)		Thread Pitch Diameter
					A	B	
C-SLN050	1/2"	14	50	500	1.120	0.260	0.787-0.797
C-SLN075	3/4"	14	50	500	1.370	0.270	0.999-1.009
C-SLN100	1"	11-1/2	25	250	1.750	0.280	1.250-1.260
C-SLN125	1 1/4"	11-1/2	10	100	2.060	0.320	1.595-1.605
C-SLN150	1 1/2"	11-1/2	10	100	2.370	0.320	1.837-1.847
C-SLN200	2"	11-1/2	10	100	2.870	0.320	2.307-2.317
C-SLN250	2 1/2"	8	—	25	3.430	0.320	2.777-2.788
C-SLN300	3"	8	—	25	4.120	0.320	3.403-3.414
C-SLN350	3-1/2"	8	—	25	4.620	0.320	3.892-3.904
C-SLN400	4"	8	—	25	5.180	0.320	4.399-4.411
C-SLN500	5"	8	—	5	6.670	0.500	5.488-5.500
C-SLN600	6"	8	—	5	7.830	0.520	6.545-6.557



Male Union

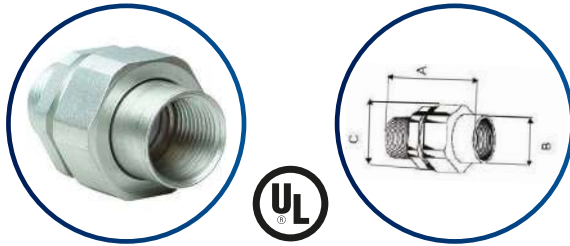

Applications:

- Indoor or outdoor use
- To connect conduit to a conduit fitting, junction box or device enclosure

Standard Material

- Steel - electrogalvanized

Catalog Number	Size	A	Dimensions B	C	Male	Female
UNY050	1/2"	56	26	38	NPT	NPSM
UNY075	3/4"	59	32	44	NPT	NPSM
UNY100	1"	64	39	53	NPT	NPSM
UNY125	1 1/4"	75	47	65	NPT	NPSM
UNY150	1 1/2"	76	55	70	NPT	NPSM
UNY200	2"	78	67	82	NPT	NPSM
UNY300	3"	95	97	120	NPT	NPSM
UNY400	4"	96	120	140	NPT	NPSM

Female Union

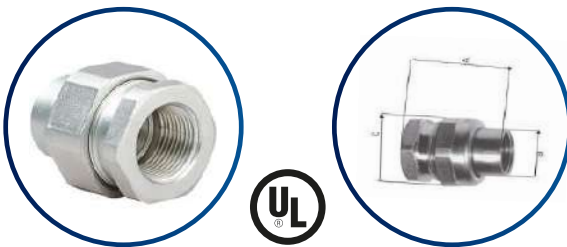

Applications:

- Indoor or outdoor use
- To connect conduit to a conduit fitting, junction box or device enclosure

Standard Material

- Steel - electrogalvanized

Catalog Number	Size	A	Dimensions B	C	Male	Female
UNF050	1/2"	56	26	38	NPSL	NPSL
UNF075	3/4"	59	32	44	NPSL	NPSL
UNF100	1"	64	39	53	NPSL	NPSL
UNF125	1 1/4"	75	47	65	NPSL	NPSL
UNF150	1 1/2"	76	55	70	NPSL	NPSL
UNF200	2"	78	67	82	NPSL	NPSL
UNF300	3"	95	97	120	NPSL	NPSL
UNF400	4"	96	120	140	NPSL	NPSL

ITCC



**CONDUIT BODIES**

### Conduit Bodies with Cover & Gasket

Combination (EMT / IMC / RIGID)

LL Type

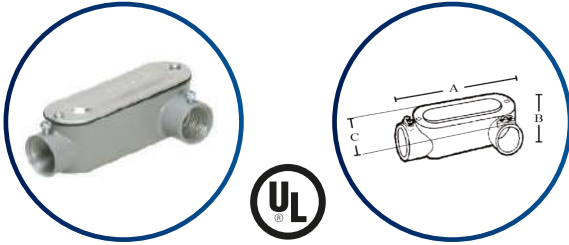

**Features:**

- Set screw and threaded LL type with cover and gasket
- Suitable for use in concrete
- NPT Tapered hubs
- NEMA FB1 rated for wet locations use with threaded rigid metal conduit only

**Applications:**

- Provides access to conductors for pulling, splicing and maintenance.

**Standard Material**

- Copper free aluminium die cast
- Steel screws

**Standard finish**

- Powder coat

Catalog Number	Size	Wire Size		Unit Carton	Ship Case	Dimensions		
		Max. No.	Max. Size			A	B	C
LL-50-CG	1/2"	2	6AWG	10	100	4.296	1.310	2.060
LL-75-CG	3/4"	2	6AWG	10	50	5.090	1.625	2.330
LL-100-CG	1"	3	5AWG	5	25	5.915	1.900	2.650
LL-125-CG	1-1/4"	3	2AWG	2	10	7.894	2.770	3.385
LL-150-CG	1-1/2"	3	2AWG	2	10	7.894	2.770	3.385
LL-200-CG	2"	3	2/0AWG	1	5	10.134	3.335	3.810
LL-250-CG	2 1/2"	3	4/0AWG	—	1	12.500	5.437	4.450
LL-300-CG	3"	3	250MCM	—	1	12.500	5.657	4.450
LL-350-CG	3 1/2"	3	350MCM	—	1	15.500	6.922	5.500
LL-400-CG	4"	4	350MCM	—	1	15.500	6.922	5.500

\* Malleable Iron Conduit Bodies are available upon request

### Combination (EMT / IMC / RIGID)

LR Type

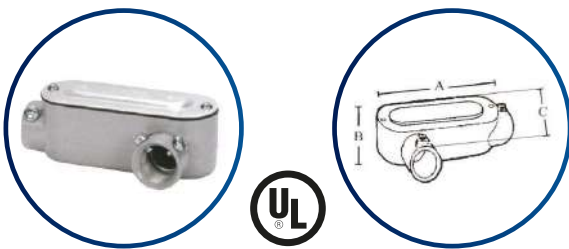

**Features:**

- Set screw and threaded LR type
- Suitable for use in concrete
- NPT Tapered hubs
- NEMA FB1 rated for wet locations use with threaded rigid metal conduit only

**Applications:**

- Provides access to conductors for pulling, splicing and maintenance.

**Standard Material**

- Copper free aluminium die cast
- Steel screws

**Standard Finish**

- Powder coat

Catalog Number	Size	Wire Size		Unit Carton	Ship Case	Dimensions		
		Max. No.	Max. Size			A	B	C
LR-50-CG	1/2"	2	6AWG	10	100	4.295	1.310	2.060
LR-75-CG	3/4"	2	6AWG	10	50	5.090	1.625	2.330
LR-100-CG	1"	3	5AWG	5	25	5.915	1.900	2.650
LR-125-CG	1-1/4"	3	2AWG	2	10	7.894	2.770	3.385
LR-150-CG	1-1/2"	3	2AWG	2	10	7.894	2.770	3.385
LR-200-CG	2"	3	2/0AWG	1	5	10.134	3.335	3.810
LR-250-CG	2 1/2"	3	4/0AWG	—	1	12.500	5.437	4.450
LR-300-CG	3"	3	250MCM	—	1	12.500	5.657	4.450
LR-350-CG	3 1/2"	3	350MCM	—	1	15.500	6.922	5.500
LR-400-CG	4"	4	350MCM	—	1	15.500	6.922	5.500

\* Malleable Iron Conduit Bodies are available upon request

**Conduit Bodies With Cover and Gasket**

Combination (EMT / IMC / RIGID)

LB Type

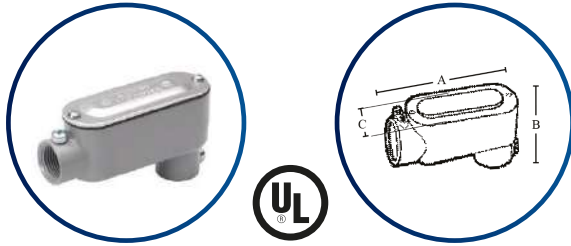

**Features:**

- Set screw and threaded LB type with cover and gasket
- Suitable for use in concrete
- NPT Tapered hubs
- NEMA FBI rated for wet locations use with threaded rigid metal conduit only

**Applications:**

- Provides access to conductors for pulling, splicing and maintenance.

**Standard Material**

- Copper free aluminium die cast

**Standard finish**

- Steel screws
- Powder coat

Catalog Number	Size	Wire Size		Unit Carton	Ship Case	Dimensions		
		Max. No.	Max. Size			A	B	C
LB-50-CG	1/2"	2	6AWG	10	100	4.560	2.060	1.310
LB-75-CG	3/4"	2	6AWG	10	50	5.090	2.430	1.540
LB-100-CG	1"	3	6AWG	5	25	5.915	2.765	1.740
LB-125-CG	1-1/4"	3	2AWG	2	10	7.894	3.665	2.490
LB-150-CG	1-1/2"	3	2AWG	2	10	7.894	3.665	2.490
LB-200-CG	2"	3	2/0AWG	1	5	10.134	4.275	3.100
LB-250-CG	2 1/2"	3	2/0AWG	—	1	12.500	5.437	4.450
LB-300-CG	3"	3	4/0AWG	—	1	12.500	5.657	4.450
LB-350-CG	3 1/2"	3	500MCM	—	1	15.500	6.922	5.500
LB-400-CG	4"	3	500MCM	—	1	15.500	6.922	5.500

\* Malleable Iron Conduit Bodies are available upon request

Combination (EMT / IMC / RIGID)

C Type

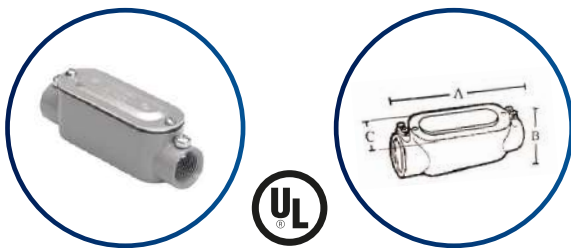

**Features:**

- Suitable Set screw and threaded C type with cover and gasket
- Suitable for use in concrete
- NPT Tapered hubs
- NEMA FBI rated for wet locations use with threaded rigid metal conduit only

**Applications:**

- Provides access to conductors for pulling, splicing and maintenance.

**Standard Material**

- Copper free aluminium die cast

**Standard finish**

- Steel screws
- Powder coat

Catalog Number	Size	Wire Size		Unit Carton	Ship Case	Dimensions		
		Max. No.	Max. Size			A	B	C
C-50-CG	1/2"	2	6AWG	5	100	4.720	1.370	1.330
C-75-CG	3/4"	2	6AWG	5	50	5.570	1.625	1.540
C-100-CG	1"	3	6AWG	5	25	6.460	1.900	1.500
C-125-CG	1-1/4"	3	2AWG	5	25	8.528	2.770	2.490
C-150-CG	1-1/2"	3	2AWG	5	10	8.258	2.770	2.490
C-200-CG	2"	3	2/0AWG	1	5	10.831	3.335	3.100
C-250-CG	2 1/2"	3	4/0AWG	—	1	13.000	4.063	5.709
C-300-CG	3"	3	250MCM	—	1	12.500	4.682	5.506
C-350-CG	3 1/2"	3	350MCM	—	1	—	5.452	6.171
C-400-CG	4"	4	350MCM	—	1	15.500	5.452	6.171

\* Malleable Iron Conduit Bodies are available upon request

**Conduit Bodies With Cover and Gasket**

Combination (EMT / IMC / RIGID)

T Type

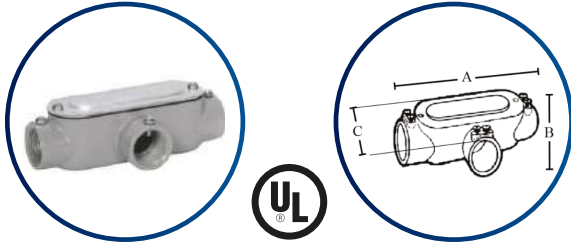

**Features:**

- Suitable Set screw and threaded T type with cover and gasket
- Suitable for use in concrete
- NPT Tapered hubs
- NEMA FB1 rated for wet locations use with threaded rigid metal conduit only

**Applications:**

- Provides access to conductors for pulling, splicing and maintenance.

**Standard Material**

- Copper free aluminium die cast
- Steel screws

**Standard finish**

- Powder coat

Catalog Number	Size	Wire Size		Unit Carton	Ship Case	Dimensions		
		Max. No.	Max. Size			A	B	C
T-50-CG	1/2"	1	6AWG	10	100	4.720	1.370	2.060
T-75-CG	3/4"	2	6AWG	10	50	5.570	1.625	2.335
T-100-CG	1"	3	6AWG	10	100	6.460	1.900	2.705
T-125-CG	1-1/4"	3	2AWG	2	10	8.528	2.770	3.630
T-150-CG	1-1/2"	3	2AWG	2	10	8.528	2.770	3.630
T-200-CG	2"	3	2/0AWG	—	2	10.831	3.335	3.980
T-250-CG	2 1/2"	3	4/0AWG	—	1	13.500	4.060	5.825
T-300-CG	3"	3	250MCM	—	1	13.500	4.685	5.825
T-350-CG	3 1/2"	3	500MCM	—	1	15.937	5.450	7.060
T-400-CG	4"	3	500MCM	—	1	15.937	5.450	7.060

\* Malleable Iron Conduit Bodies are available upon request

Combination (EMT / IMC / RIGID)

X Type

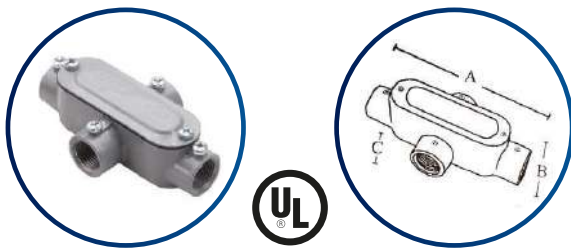

**Features:**

- Suitable Set screw and threaded X type with cover and gasket
- Suitable for use in concrete
- NPT Tapered hubs
- NEMA FB1 rated for wet locations use with threaded rigid metal conduit only

**Applications:**

- Provides access to conductors for pulling, splicing and maintenance.

**Standard Material**

- Copper free aluminium die cast
- Steel screws

**Standard finish**

- Powder coat

Catalog Number	Size	Wire Size		Unit Carton	Ship Case	Dimensions		
		Max. No.	Max. Size			A	B	C
X-50-CG	1/2"	2	6AWG	5	50	4.750	2.690	1.850
X-75-CG	3/4"	2	6AWG	5	25	5.500	3.000	1.880
X-100-CG	1"	3	6AWG	2	10	6.500	3.500	2.150
X-125-CG	1-1/4"	3	2AWG	1	5	8.250	4.500	2.750
X-150-CG	1-1/2"	3	2AWG	1	5	8.250	4.500	2.750
X-200-CG	2"	3	2/0AWG	1	2	10.500	5.380	3.630
X-250-CG	2 1/2"	3	4/0AWG	—	1	13.500	5.380	5.825
X-300-CG	3"	3	250MCM	—	1	13.000	5.450	5.825
X-350-CG	3 1/2"	3	350MCM	—	1	15.950	5.450	7.060
X-400-CG	4"	4	350MCM	—	1	15.950	5.450	7.060

\* Malleable Iron Conduit Bodies are available upon request

### Conduit Body Cover

Zinc Plated Steel with Screws

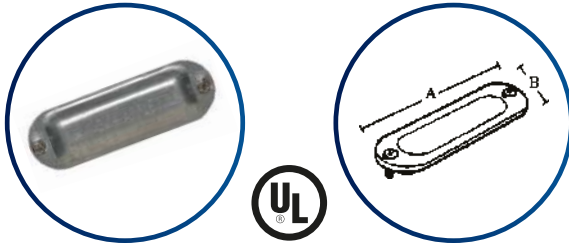

**Features:**

- Domed design allows for additional wiring space
- Suitable for use in concrete
- Includes screws

**Applications:**

- Designed to use with ITCC Conduit Bodies; interchangeable with all major brands

**Standard Material**

- Steel

**Standard finish**

- Zinc plated

Catalog Number	Size	Unit Carton	Ship Case	Dimensions	
				A	B
SC050	1/2"	25	250	3.875	1.310
SC075	3/4"	25	250	4.625	1.520
SC100	1"	10	100	5.315	1.710
SC125 & SC150	1-1/4" - 1-1/2"	—	25	7.240	2.510
SC200	2"	—	25	9.484	3.110
SC250 & SC300	2 1/2" - 3"	—	10	12.187	4.440
SC350 & SC400	3 1/2" - 4"	—	5	14.937	5.500

### Conduit Body Gaskets

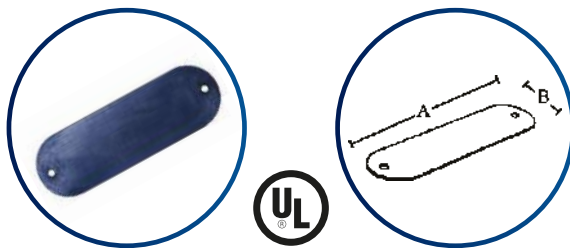

**Features:**

- Provides dust proof seal between conduit body and cover to protect from hazardous elements
- Fits all Form 5LB, LL, LR, C and T-type conduit bodies and covers

**Applications:**

- For use with ITCC Conduit Bodies 1/2" - 4"

**Standard Material**

- Neoprene

Catalog Number	Size	Unit Carton	Ship Case	Dimensions	
				A	B
G050	1/2"	50	500	3.935	1.360
G075	3/4"	50	500	4.600	1.550
G00	1"	25	500	5.370	1.760
G125 & G150	1-1/4" - 1-1/2"	25	500	7.250	2.500
G200	2"	25	250	9.500	3.070
G250 & G300	2 1/2" - 3"	10	100	12.125	4.360
G350 & G400	3 1/2" - 4"	5	50	14.812	5.400

ITCC



**FLEXIBLE METALIC  
CONDUIT FITTINGS**

### Flexible Squeeze Connectors

Straight - Squeeze Type - Zinc Die Cast



**Features:**

- Squeeze type straight
- Available with insulated throat

**Applications:**

- Indoor use only
- In a dry location, use to connect flexible metallic conduit to a steel outlet box, load center or other metal enclosure

**Standard Material**

- Zinc die cast

Catalog Number	Size	Unit Carton	Ship Case	Dimensions			Screws
				A	B	C	
CFSC050	1/2"	25	250	1.378	0.563	0.394	1
CFSC075	3/4"	25	250	1.496	1.114	0.433	1
CFSC100	1"	10	100	1.673	1.389	0.492	1
CFSC125	1-1/4"	10	100	1.862	1.642	0.563	1
CFSC150	1-1/2"	5	50	1.957	1.961	0.691	1
CFSC200	2"	10	40	2.134	2.461	0.669	1
CFSC250	2 1/2"	—	10	2.815	2.362	0.847	2
CFSC300	3"	—	10	3.209	2.953	0.847	2
CFSC350	3 1/2"	—	1	4.190	3.750-4.100	1.030	2
CFSC400	4"	—	1	3.957	3.819	0.886	2

\* Insulated models are also available. Please add "I" to the Part Number while ordering "CFSC050I"

### 90° - Squeeze Type - Zinc

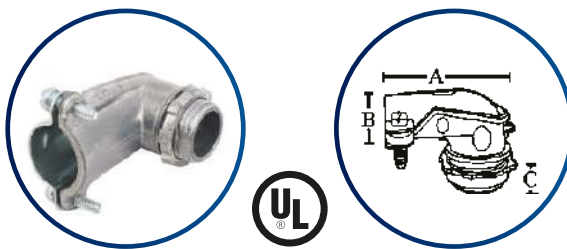

**Features:**

- Squeeze type

**Applications:**

- Indoor use only
- In a dry location, use to connect flexible metallic conduit to a steel outlet box, or other metal enclosure

**Standard Material**

- Zinc die cast
- Zinc plated steel strap

Catalog Number	Size	Unit Carton	Ship Case	Dimensions			Screws
				A	B	C	
CFSC9050	1/2"	25	250	2.110	0.640-1.030	0.400	2
CFSC9075	3/4"	10	100	2.400	0.760-1.150	0.400	2
CFSC9100	1"	5	50	2.870	1.090-1.730	0.540	2
CFSC9125	1-1/4"	10	40	4.000	1.340-1.970	0.640	2
CFSC9150	1-1/2"	—	5	6.000	1.650-2.610	0.750	2
CFSC9200	2"	—	5	6.000	1.540-2.540	0.740	2
CFSC9250	2 1/2"	—	5	7.187	2.450-2.980	0.875	4
CFSC9300	3"	—	2	7.875	2.930-3.450	1.031	4
CFSC9350	3 1/2"	—	1	9.400	3.280-3.950	1.031	4
CFSC9400	4"	—	1	10.200	3.680-4.430	1.031	4

\* Insulated models are also available. Please add "I" to the Part Number while ordering "CFSC9050I"



### Straight Liquidtight Connectors

Zinc

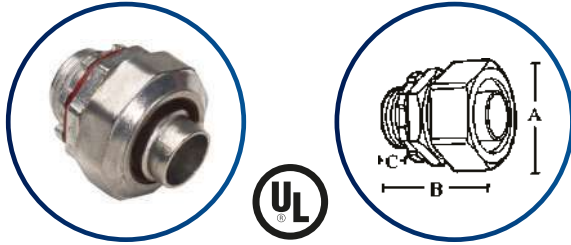

- Features:**
- Straight component type connectors
  - Assembled with a die cast locknut
- Applications:**
- To secure, ground and seal liquidtight conduit to a box or enclosure
- Standard Material**
- Zinc die cast

Catalog Number	Size	Unit Carton	Ship Case	A	Dimensions B	C
CFLT050	1/2"	20	200	1.283	1.209	0.484
CFLT075	3/4"	10	100	1.527	1.244	0.488
CFLT100	1"	5	50	1.772	1.457	0.591
CFLT125	1-1/4"	5	50	2.213	1.725	0.669
CFLT150	1-1/2"	2	20	2.480	1.756	0.669
CFLT200	2"	2	20	2.953	1.732	0.630
CFLT250	2 1/2"	—	1	3.543	2.559	0.945
CFLT300	3"	—	1	4.252	2.795	0.984
CFLT350	3 1/2"	—	1	3.660	5.470	0.920
CFLT400	4"	—	1	5.236	2.992	1.102

### 90° Liquidtight Connectors

Zinc

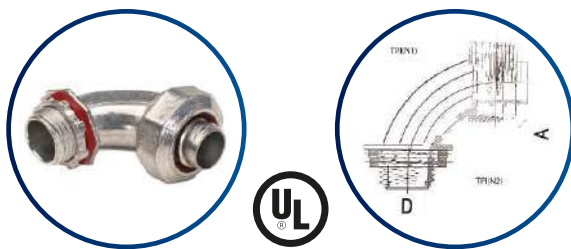

- Features:**
- 90° component type connectors
  - Assembled with a die cast locknut
- Applications:**
- To secure, ground and seal liquidtight conduit to a box or enclosure
- Standard Material**
- Zinc die cast

Catalog Number	Size	A	Dimensions B	C	D	TPI (N1)	TPI (N2)	No. of Lock nuts used
CFLT9050	1/2"	1.490	1.490	1.283	0.565	18	14	1
CFLT9075	3/4"	1.606	1.606	1.527	0.747	18	14	1
CFLT9100	1"	1.976	1.976	1.772	0.949	18	11.5	1
CFLT9125	1-1/4"	2.256	2.256	2.121	1.248	16	11.5	1
CFLT9150	1-1/2"	2.492	2.492	2.480	1.516	16	11.5	1
CFLT9200	2"	2.811	2.811	2.953	1.909	16	11.5	1
CFLT9250	2 1/2"	4.259	4.259	3.543	2.402	14	8	1
CFLT9300	3"	3.961	3.961	4.252	2.961	14	8	1
CFLT9400	4"	4.134	4.134	5.236	3.799	14	8	1

### Straight Liquidtight Connectors

With Grounding Lug - Zinc / Malleable Iron

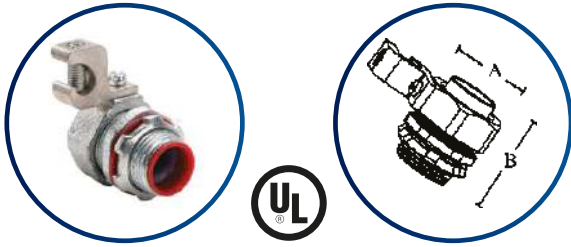

**Features:**

- Liquidtight
- Lay-in grounding lug
- Insulated throat protects conductors from abrasion damage
- Zinc electro plated for excellent durability

**Applications:**

- Use to connect liquidtight conduit and terminate an external bonding conductor

**Standard Material**

- Zinc / Malleable iron
- Steel locknut
- Aluminium lug

**Standard Finish**

- Zinc plated

Catalog Number	Size	Lug Size	Ship Case	Dimensions	
				A	B
E-LTC 50-GR	1/2"	14-4	10	1.360	1.730
E-LTC 75-GR	3/4"	14-4	5	1.610	1.810
E-LTC 100-GR	1"	14-4	5	1.890	1.850
E-LTC 125-GR	1-1/4"	14-4	2	2.390	2.050
E-LTC 150-GR	1-1/2"	14-4	2	2.620	2.380
E-LTC 200-GR	2"	14-4	2	3.240	2.490
E-LTC 250-GR	2 1/2"	1/0-14	—	3.890	3.210
E-LTC 300-GR	3"	1/0-14	—	4.740	3.370
E-LTC 350-GR	3 1/2"	6/250	—	5.310	3.400
E-LTC 400-GR	4"	6/250	—	5.820	3.660

### 90° Liquidtight Connectors

With Grounding Lug - Zinc / Malleable Iron

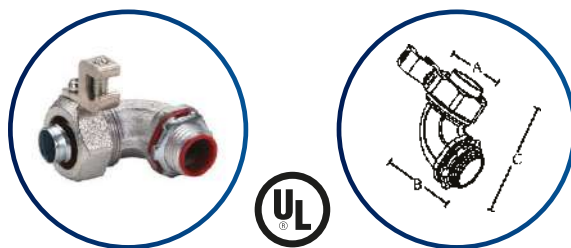

**Features:**

- Liquidtight
- Lay-in grounding lug
- Insulated throat protects conductors from abrasion damage
- Zinc electro plated for excellent durability

**Applications:**

- Use to connect liquidtight conduit and terminate an external bonding conductor that runs parallel to the conduit

**Standard Material**

- Zinc / Malleable iron
- Steel locknut
- Aluminium lug

**Standard Finish**

- Zinc plated

Catalog Number	Size	Lug Size	Unit Carton	Ship Case	Dimensions		
					A	B	C
E-LTC 50-90-GR	1/2"	14-4	5	50	1.360	2.100	2.540
E-LTC 75-90-GR	3/4"	14-4	2	20	1.610	2.450	2.820
E-LTC 100-90-GR	1"	14-4	2	20	1.890	2.830	3.080
E-LTC 125--90GR	1-1/4"	14-4	2	20	2.390	3.150	3.530
E-LTC 150-90-GR	1-1/2"	14-4	2	20	2.620	3.500	4.170
E-LTC 200-90-GR	2"	14-4	2	20	3.240	4.020	4.690
E-LTC 250-90-GR	2 1/2"	1/0-14	—	1	3.890	6.230	6.740
E-LTC 300-90-GR	3"	1/0-14	—	1	4.740	6.910	7.520
E-LTC 350-90-GR	3 1/2"	6/250	—	1	5.310	7.570	7.930
E-LTC 400-90-GR	4"	6/250	—	1	5.820	8.070	8.720

ITCC

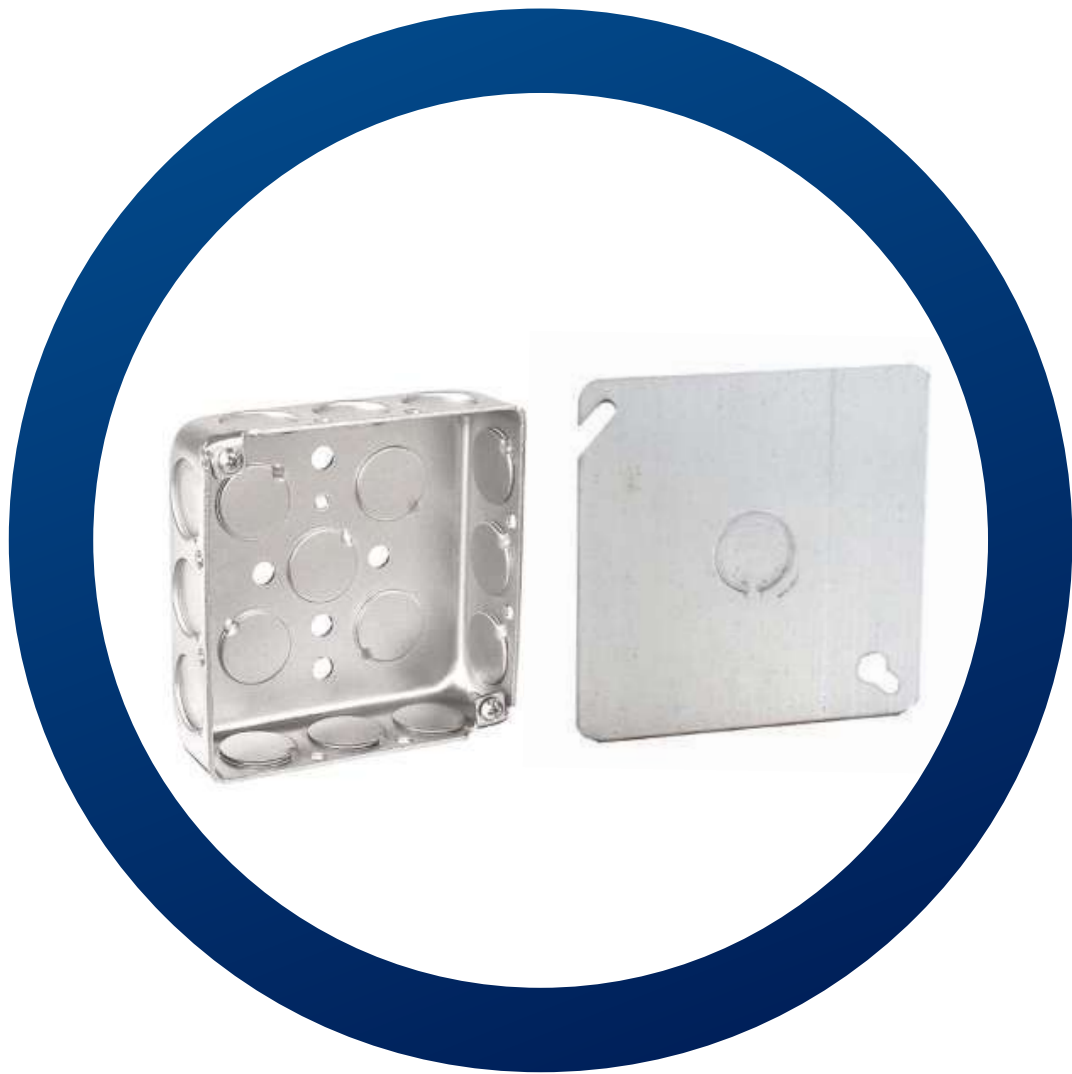

**UTILITY BOXES  
& COVERS**

4" Octagonal Boxes, Drawn  
 4" Octagonal Boxes, Deep, Drawn  
 4" Octagonal Covers



**Features:**

- Boxes - Drawn
- Boxes - 1-1/2" & 2-1/8" deep
- Boxes 15.5 & 21.5 cu. in.
- Available in multiple KO sizes, with or without concentric KOs and raised ground emboss with installed 10-32 ground screw where noted.

**Applications**

- 4" octagon junction boxes are used to install ceiling and wall lighting fixtures, fans or convenience outlets and devices.
- Octagon boxes are used to bring power to an electrical device where multiple conductor runs are split in two or more directions
- 4" octagon blank flat covers are used to cover 4" octagon box wiring and provide a means for access when future conduit runs are required

**Standard Material**

Galvanized steel

Catalog Number	Description	Knockouts		Cubic Inches	Ship Case
		Sides	Bottom		
<b>BOXES</b>					
54151-1/2"	OCTAGONAL DRAWN BOXES 92.2 X 92.2 X 38.8 X 1.60MM	(1/2)-4	(1/2)-4	15.5	50
54151-3/4"	OCTAGONAL DRAWN BOXES 92.2 X 92.2 X 38.8 X 1.60MM	(3/4)-4	(3/4)-2 & (1/2)-2	15.5	50
54151 - 1/2" & 3/4"	OCTAGONAL DRAWN BOXES 92.2 X 92.2 X 38.8 X 1.60MM	(3/4)-2 & (1/2)-2	(3/4)-2 & (1/2)-2	15.5	50
54171-1/2"	OCTAGONAL DRAWN BOXES 92.2 X 92.2 X 54 X 1.60MM	(1/2)-4	(1/2)-4	21.5	50
54171-3/4"	OCTAGONAL DRAWN BOXES 92.2 X 92.2 X 54 X 1.60MM	(3/4)-4	(3/4)-2 & (1/2)-2	21.5	50
54171-1/2 & 3/4"	OCTAGONAL DRAWN BOXES 92.2 X 92.2 X 54 X 1.60MM	(3/4)-2 & (1/2)-2	(3/4)-2 & (1/2)-2	21.5	50
54171-1"	OCTAGONAL DRAWN BOXES 92.2 X 92.2 X 54 X 1.60MM	(1)-4	(3/4)-2 & (1/2)-2	21.5	50
<b>COVERS</b>					
54C1	OCTANGONAL COVERS BLANK FLAT (1) HOLE & (1) SLOT 96 X 96 X 1.60MM			—	100
54C6	OCTANGONAL COVERS (1) 1/2 KO, (1) HOLE & (1) SLOT 96 X 96 X 1.60MM			—	100

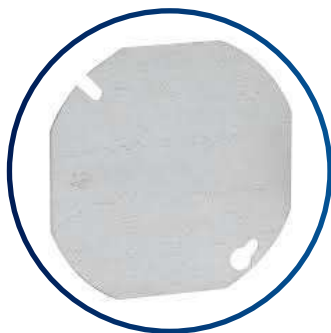

54C1



54C6

4" Utility Boxes, Drawn



**Features:**

- Boxes - Drawn
- Boxes - 1-7/8" & 2-1/8" deep
- Boxes 15.5 & 21.5 cu. in.
- Available in multiple KO sizes, with or without concentric KOs

**Applications**

- Handy boxes, also referred to as utility boxes are used for switch boxes, convenience outlets or small junction boxes in exposed work applications
- Great for appliances and machinery
- ITCC handy utility boxes have a small, rectangular design that enables power outlets and switches to be installed in small places
- Can easily be customized with special holes or knockouts for OEM applications

**Standard Material**

- Galvanized steel

Catalog Number	Description	Sides	Knockouts	Bottom	Cubic Inches	Ship Case
<b>BOXES</b>						
58361-1/2"	RECTANGULAR BOXES 103 X 46 X 1.60MM	(1/2)-8		(1/2)-2	13.0	50
58361-3/4"	RECTANGULAR BOXES 103 X 46 X 1.60MM	(3/4)-6		(3/4)-1	13.0	50
58631 - 1/2" & 3/4"	RECTANGULAR BOXES 103 X 46 X 1.60MM	(1/2) - 4 & (3/4) 4		(1/2)-1 & (3/4)-1	13.0	50
58371-1/2"	RECTANGULAR BOXES 103 X 54 X 1.60MM	(1/2)-8		(1/2)-2	14.5	50
54171-3/4"	RECTANGULAR BOXES 103 X 54 X 1.60MM	(3/4)-6		(3/4)-1	14.5	50
58371-1/2" & 3/4"	RECTANGULAR BOXES 103 X 54 X 1.60MM	(1/2) - 4 & (3/4) 4		(1/2)-1 & (3/4)-1	14.5	50
58371-1"	RECTANGULAR BOXES 103 X 54 X 1.60MM	(1)-6		(3/4)-1	14.5	50
<b>COVERS</b>						
58C1	RECTANGULAR (UTILITY) COVER BLANK FLAT 108.6 X 59 X 1.60MM				—	100
58C6	RECTANGULAR (UTILITY) FLAT WITH 1/2" KO 108.6 X 59 X 1.60MM				—	100



58C1



58C6

**4" Square Boxes, Drawn**  
**4" Square Boxes, Deep, Drawn**  
**4" Square Covers**



**Features:**

- Drawn
- 1-1/2" & 2-1/8" deep
- Available in multiple KO sizes, with or without concentric KOs

**Applications**

- 4" square drawn junction boxes can be installed in walls or ceilings for lightning fixtures, switches, receptacles or other outlet devices. Square boxes are used to bring power to a number of electrical devices where multiple conductor runs are split in two or more directions

**Standard Material**

- Galvanized steel

Catalog Number	Description	Sides	Knockouts	Bottom	Cubic Inches	Ship Case
<b>BOXES</b>						
52151-1/2"	SQUARE DRAWN BOXES 101X101X39X1,60MM	(12)- 1/2"		(1/2)-4	21	50
52151-3/4"	SQUARE DRAWN BOXES 101X101X39X1,60MM	(8)-3/4"		(2)-1/2" & (2)-3/4"	21	50
52151 - 1/2" & 3/4"	SQUARE DRAWN BOXES 101X101X39X1,60MM	(8)-1/2" & (4)-3/4"		(2)-1/2" & (2)-3/4"	21	50
52171-1/2"	SQUARE DRAWN BOXES 101X101X54X1,60MM	(12)-1/2"		(1/2)-4	30.5	50
52171-3/4"	SQUARE DRAWN BOXES 101X101X54X1,60MM	(8)- 3/4"		(2)-1/2" & (2)-3/4"	30.5	50
52171-1/2" & 3/4"	SQUARE DRAWN BOXES 101X101X54X1,60MM	(8)-1/2" & (4)-3/4"		(2)-1/2" & (2)-3/4"	30.5	50
52171-1"	SQUARE DRAWN BOXES 101X101X54X1,60MM	(8)-1"		(2)-1/2" & (2)-3/4"	30.5	50
<b>COVERS</b>						
52C1	SQUARE COVERS BLANK FLAT (1) HOLE & (1) SLOT (104 X 104.2 X1.60)MM				—	100
52C6	SQUARE COVERS FLAT (1) 1/2 KO, (1) HOLE & (1) SLOT (104 X 104.2 X1.60)MM				—	100



**52C1**



**52C6**

ITCC



**STRUT CHANNELS  
AND ACCESSORIES**

### 41x41 Plain / Slotted Unistrut Channel

- PL: Plain
- SL: Slotted
- PG: Pre-galvanized
- EG: Electro-galvanized
- HDG: Hot dip galvanized
- SS: Stainless Steel

Catalog Number	Dim		Thickness	
	in	mm	gauge	mm
USC-C025	1-5/8 X 1-5/8"	41X41	12	2.5
USC-C020	1-5/8 X 1-5/8"	41X41	14	2.0
USC-C015	1-5/8 X 1-5/8"	41X41	16	1.5
USC-C012	1-5/8 X 1-5/8"	41X41	18	1.2

Standard length 10ft. / 3.0 meter. Other length, thickness available

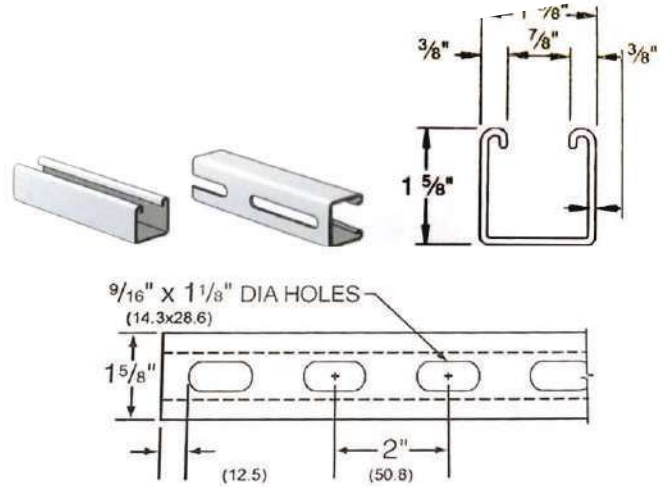

### 41x21 Plain / Slotted Unistrut Channel

- PL: Plain
- SL: Slotted
- PG: Pre-galvanized
- EG: Electro-galvanized
- HDG: Hot dip galvanized
- SS: Stainless Steel

Catalog Number	Dim		Thickness	
	in	mm	gauge	mm
USC-C125	1-5/8 X 13/16"	41X21	12	2.5
USC-C120	1-5/8 X 13/16"	41X21	14	2.0
USC-C115	1-5/8 X 13/16"	41X21	16	1.5
USC-C112	1-5/8 X 13/16"	41X21	18	1.2

Standard length 10ft. / 3.0 meter. Other length, thickness available

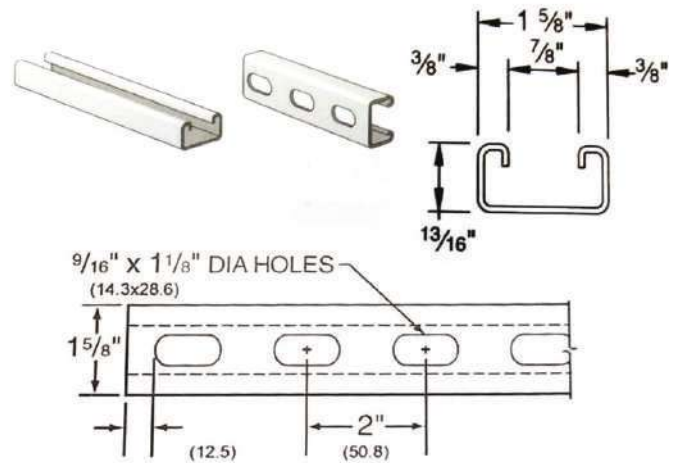



EMT Strut Clamps

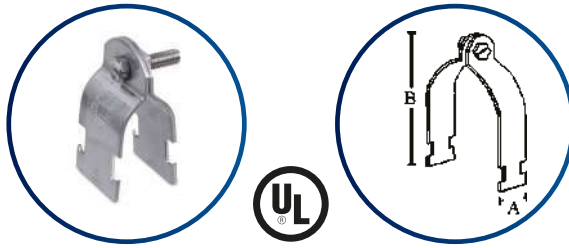

- Features:**  
 · For use with EMT conduit  
**Applications:**  
 · Use to support EMT conduit from strut channel  
**Standard Material**  
 · Steel  
**Standard Finish**  
 · Zinc plated

Catalog Number	Size	Conduit Size mm	Material Thickness	A	B
USC-E050	1/2"	17.93	0.060 ± 0.005	1.25	2.23
USC-E075	3/4"	23.42	0.060 ± 0.005	1.25	2.42
USC-E100	1"	29.54	0.075 ± 0.005	1.25	2.77
USC-E125	1-1/4"	38.35	0.075 ± 0.005	1.25	3.09
USC-E150	1-1/2"	44.20	0.105 ± 0.005	1.25	3.38
USC-E200	2"	60.33	0.105 ± 0.005	1.25	3.77
USC-E250	2 1/2"	73.03	0.105 ± 0.005	1.25	4.47
USC-E300	3"	88.90	0.105 ± 0.005	1.25	5.08
USC-E350	3 1/2"	101.60	0.118 ± 0.005	1.25	5.74
USC-E400	4"	114.30	0.118 ± 0.005	1.25	6.30

Rigid Strut Clamps

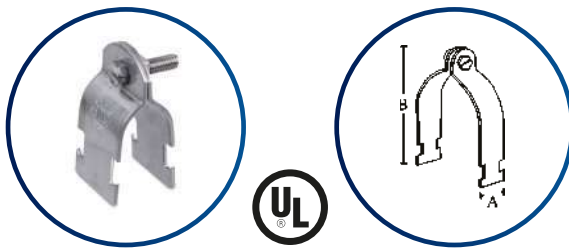

- Features:**  
 · For use with IMC / Rigid conduit  
**Applications:**  
 · Use to support IMC / Rigid conduit from strut channel  
**Standard Material**  
 · Steel  
**Standard Finish**  
 · Zinc plated

Catalog Number	Size	Conduit Size mm	Material Thickness	A	B
USC-R050	1/2"	21.34	0.0641 ± 0.005	1.25	2.23
USC-R075	3/4"	26.67	0.0641 ± 0.005	1.25	2.42
USC-R100	1"	33.40	0.0747 ± 0.005	1.25	2.77
USC-R125	1-1/4"	42.16	0.0747 ± 0.005	1.25	3.09
USC-R150	1-1/2"	48.26	0.1034 ± 0.005	1.25	2.38
USC-R200	2"	60.33	0.1034 ± 0.005	1.25	3.77
USC-R250	2 1/2"	73.03	0.1034 ± 0.005	1.25	4.47
USC-R300	3"	88.90	0.1034 ± 0.005	1.25	5.08
USC-R350	3 1/2"	101.60	0.118 ± 0.005	1.25	5.74
USC-R400	4"	114.30	0.118 ± 0.005	1.25	6.30
USC-R500	5"	141.30	0.118 ± 0.005	1.25	7.65
USC-R600	6"	168.30	0.118 ± 0.005	1.25	8.70



# **MISCELLANEOUS ACCESSORIES**

## Aluminum Conduit Benders



### FEATURES:

- Lightweight aluminium construction for easy handling
- Heat treated for extra strength-reinforced as stress points for longer life
- Precision-located degree scale, star, arrow and rim notch for perfect bends everytime
- Markings are raised and cast into bender body on both sides for easy visibility

### BENEFITS:

- Deeply serrated step helps prevent slippage when applying maximum leverage.
- Grooved internal hook surface helps prevent conduit from slipping
- Flat hok surface provides stable starting point

Catalog Number	Conduit Type & Size
840AH	1/2" EMT
841AH	3/4" EMT, 1/2" IMC/RIGID
842AH	1" EMT, 3/4" IMC/RIGID
843AH	1 1/4" EMT, 1" IMC/RIGID

## Universal Strut Clamps

EMT and Rigid

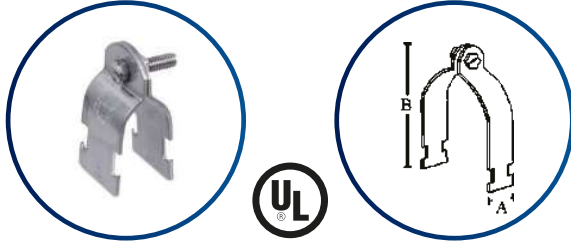

**Features:**

- For use with EMT/Rigid and IMC conduit
- All screws - 5/16" x 1-1/4" slotted hex head

**Applications:**

- Used to support stationary pipe and tubing lines from strut channel

**Standard Material**

- Steel
- Standard finish**
- Zinc plated

Catalog Number	Size	Ship Case	Dimensions	
			A	B
USC050	1/2"	100	1.25	2.23
USC075	3/4"	100	1.25	2.42
USC100	1"	100	1.25	2.77
USC125	1-1/4"	100	1.25	3.09
USC150	1-1/2"	50	1.25	3.38
USC200	2"	50	1.25	3.77
USC250	2 1/2"	50	1.25	4.47
USC300	3"	25	1.25	5.08
USC350	3 1/2"	25	1.25	5.74
USC400	4"	25	1.25	6.30

## Conduit Hangers

With Bolt & Nut Attached - Steel

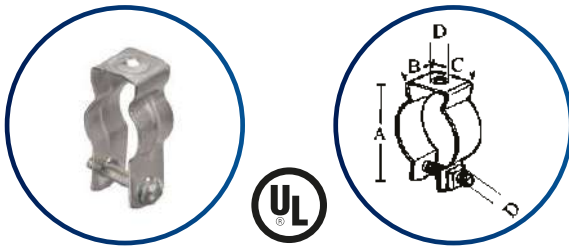

**Features:**

- Assembled with nut and bolt

**Applications:**

- Indoor or outdoor use
- Use to secure and suspend conduit from overhead supports

**Standard Material**

- Steel
- Standard finish**
- Zinc plated

Catalog Number	Size	For Rigid & EMT	Bolt Size	Ship Case	Dimensions			
					A	B	C	D
C-HAN050	0	1/2"	1/4"-20	100	1.960	0.750	0.725	0.250
C-HAN075	1	3/4"	1/4"-20	100	2.160	0.750	0.850	0.250
C-HAN100	2	1"	1/4"-20	100	2.490	0.870	0.975	0.250
C-HAN125	3	1-1/4"	1/4"-20	100	2.490	0.870	0.975	0.250
C-HAN150	4	1-1/2"	1/4"-20	100	3.470	0.980	1.125	0.250
C-HAN200	5	2"	1/4"-20	50	3.990	0.980	1.145	0.250
C-HAN250	6	2 1/2"	5/16"-18	50	5.170	1.260	1.225	0.312
C-HAN300	7	3"	5/16"-18	25	5.600	1.260	1.275	0.312
C-HAN350	8	3 1/2"	5/16"-18	25	5.750	1.250	1.275	0.312
C-HAN400	9	4"	5/16"-18	25	6.960	1.260	1.275	0.312

## Combination Couplings

Screw In Type - EMT Compression to Flex - Zinc Die Cast

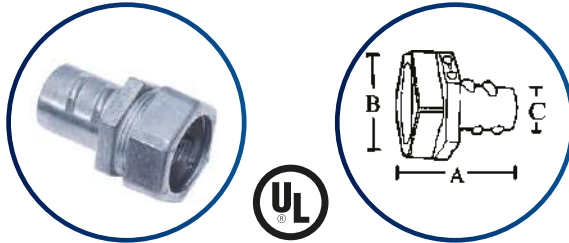

**Features:**

- Screw in to compression type
- Combination coupling used to join flexible metal conduit to EMT

**Applications:**

- Indoor use only
- Use to join EMT conduit to flexible metallic conduit
- Suitable for: 1/2" steel, steel reduced wall, and aluminium flexible metal conduit to EMT, 3/4"-1" flexible metal conduit to EMT

**Standard Material**

- Zinc die cast

Catalog Number	Size	Unit Carton	Ship Case	Dimensions		
				A	B	C
CPEF050	1/2" - 1/2"	50	500	1.660	1.000	0.723
CPEF075	3/4" - 3/4"	25	250	1.680	1.180	0.931
CPEF100	1" - 1"	25	250	1.895	1.625	1.070

## Compression Type EMT to Rigid - Steel

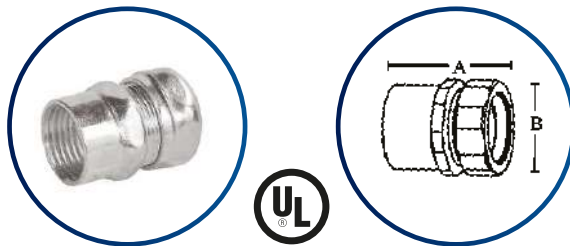

**Features:**

- Internally threaded for Rigid/IMC conduit
- Compression type EMT
- Rain-tight

**Applications:**

- Indoor use only
- Use to join Rigid/IMC conduit to EMT between 2 different raceways
- Coupling internally threaded for Rigid/IMC

**Standard Material**

- Steel

**Standard Finish**

- Zinc plated

Catalog Number	Size	Unit Carton	Ship Case	Dimensions	
				A	B
CPER050	1/2"	20	200	1.100	1.570
CPER075	3/4"	10	100	1.330	1.620
CPER100	1"	10	100	1.630	1.820

## Flex Couplings

Screw In Type

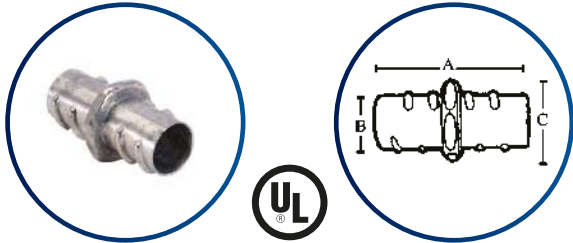

**Features:**

- Screw in coupling

**Applications:**

- Indoor use only
- Use to join two pieces of flexible metallic conduit

**Standard Material**

- Zinc die cast

Catalog Number	Size	Unit Carton	Ship Case	Dimensions		
				A	B	C
CPFF050	1/2"	50	500	1.80	0.92	1.062
CPFF075	3/4"	25	250	2.09	1.12	1.372
CPFF100	1"	25	250	2.41	1.37	1.687
CPFF125	1-1/4"	10	100	2.74	1.81	2.125
CPFF150	1-1/2"	10	40	3.05	2.12	2.375
CPFF200	2"	10	40	3.27	2.67	2.937

## Combination Couplings

Set Screw Type - EMT to Flex

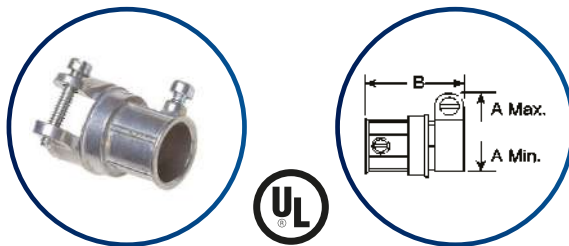

**Features:**

- Set screw type
- EMT to flex combination coupling
- UL listed

**Applications:**

- Indoor use only
- Use to join EMT conduit to flexible metal conduit

**Standard Material**

- Zinc die cast

Catalog Number	Size	Unit Carton	Ship Case	Dimensions		
				A Min.	A Max.	B
CPEF050S	1/2" - 1/2"	25	250	0.75	0.95	1.65
CPEF075S	3/4" - 3/4"	—	100	0.75	1.20	1.93
CPEF100S	1" - 1"	—	50	1.14	1.60	2.12

### Combination Couplings

Liquidtight to Rigid - Steel / Zinc Die Cast

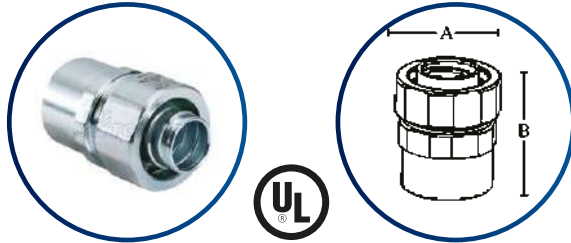

**Features:**

- Rain-tight
- Liquidtight
- NPSM thread
- Labor saving

**Applications:**

- Use to join Liquidtight Flexible Conduit to Rigid/IMC conduit between 2 different raceways.
- Suitable for use in wet locations
- Raintight, concrete tight

**Standard Material**

- Steel / Die Cast Zinc

**Standard Finish**

- Zinc plated

Catalog Number	Size	Unit Carton	Ship Case	Dimensions		
				A	B	C
E-LFC 50	1/2"	20	200	1.17"	1.78"	1.062
E-LFC 75	3/4"	10	100	1.43"	1.94"	1.372
E-LFC 100	1"	5	50	1.76"	2.19"	1.687
E-LFC 125	1-1/4"	5	50	2.16"	2.23"	2.125
E-LFC 150	1-1/2"	—	12	2.38"	2.62"	2.375
E-LFC 200	2"	—	5	2.87"	2.67"	2.937

Liquidtight to EMT - Steel / Zinc Die Cast

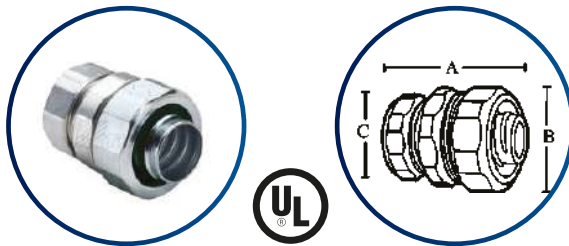

**Features:**

- EMT to Liquidtight
- Set screw type
- Reusable ferrule

**Applications:**

- Use to connect Liquidtight Flexible Conduit to EMT 1/2" - 1", ideal for rooftop HVAC air conditioners and motor hook-ups
- Can be used with EMT indoors only

**Standard Material**

- Steel / Die Cast Zinc

**Standard Finish**

- Zinc plated

Catalog Number	Size	Unit Carton	Ship Case	Dimensions		
				A Min.	A Max.	B
E-LSC 50	1/2" - 1/2"	25	250	1.64	1.39	1.09
E-LSC 75	3/4" - 3/4"	20	200	1.75	1.72	1.30
E-LSC 100	1" - 1"	10	100	2.00	1.75	1.50

ITCC



**PVC COATED RMC  
CONDUITS & FITTINGS**





With its state-of-the-art manufacturing facility in Saudi Arabia, ITCC is the only manufacturer in the region that fully produces PVC Coated RMC Conduit. This includes the Rigid Steel Conduit, the Rigid Steel Coupling, and the PVC Coating. ITCC PVC Coated RMC Conduit is manufactured as per the industry standard.

### PVC Coated Rigid Steel Conduits

PVC Coated Rigid Metallic Conduit is used for highly corrosive environments. The coating will provide corrosion protection and mechanical protection. Ground continuity is maintained throughout the installation.

#### Features:

- 40 mil anthracite grey (RAL 7016) PVC exterior coating
- Specialized corrosion resistant coating provided on threads
- One Coupling is included with each conduit

#### Standards:

- ITCC RMC conduit is UL listed with the Hot Dipped Galvanized HDG zinc coating as the primary protection as per UL6
- ARAMCO Vendor ID No. 10054780
- As per NEMA RN 1 specifications

Code	Inch	Diameter (Steel only) mm	Outside Diameter (With PVC) mm	Nominal Wall Thickness (Steel only) mm	Nominal Wall Thickness (With PVC) mm	Nominal Inside Diameter mm	Minimum Weight Per Length (Steel Only) mm
CTD-R075	3/4"	26.70	28.70	2.71	3.73	21.20	4.76
CTD-R100	1"	33.40	35.40	3.20	4.21	27.00	6.94
CTD-R125	1 1/4"	42.16	44.10	3.37	4.39	35.40	9.12
CTD-R150	1 1/2"	48.30	50.20	3.50	4.52	41.20	11.29
CTD-R200	2"	60.30	62.30	3.70	4.72	52.90	15.06
CTD-R250	2 1/2"	73.00	75.00	4.90	5.91	63.20	23.90
CTD-R300	3"	88.90	90.90	5.20	6.22	78.50	30.96
CTD-R350	3 1/2"	101.60	103.60	5.46	6.47	90.70	37.69
CTD-R400	4"	114.30	116.30	5.71	6.73	102.90	44.10
CTD-R500	5"	141.30	143.30	6.22	7.23	128.90	59.59
CTD-R600	6"	168.30	170.30	6.75	7.78	154.80	79.17

## Couplings & Bushings

### PVC COATED RMC COUPLINGS



Code	Trade Size (INCH)
CTD-RCP075	3/4"
CTD-RCP100	1"
CTD-RCP125	1 1/4"
CTD-RCP150	1 1/2"
CTD-RCP200	2"
CTD-RCP250	2 1/2"
CTD-RCP300	3"
CTD-RCP350	3 1/2"
CTD-RCP400	4"
CTD-RCP500	5"
CTD-RCP600	6"

- 40 mil gray PVC exterior coating
- Sealing sleeves on both ends

### PVC COATED BUSHING



With Grounding	Without Grounding	Trade Size inch
CTD-RBG075	CTD-RBI075	3/4"
CTD-RBG100	CTD-RBI100	1"
CTD-RBG125	CTD-RBI125	1 1/4"
CTD-RBG150	CTD-RBI150	1 1/2"
CTD-RBG200	CTD-RBI200	2"
CTD-RBG250	CTD-RBI250	2 1/2"
CTD-RBG300	CTD-RBI300	3"
CTD-RBG350	CTD-RBI350	3 1/2"
CTD-RBG400	CTD-RBI400	4"
CTD-RBG500	CTD-RBI500	5"
CTD-RBG600	CTD-RBI600	6"

\* PVC Coating service is available for other fittings upon customer's request

## Elbows

PVC COATED RMC ELBOW  
(STANDARD RADIUS)



- Fabricated from ITCC PVC Coated RMC Conduit
- Standard angles is 30°, 45°, 60°, 90° are available
- Special radius can be manufactured upon request

Code	Trade Size (INCH)
CTD-RLX075	3/4"
CTD-RLX100	1"
CTD-RLX125	1 1/4"
CTD-RLX150	1 1/2"
CTD-RLX200	2"
CTD-RLX250	2 1/2"
CTD-RLX300	3"
CTD-RLX350	3 1/2"
CTD-RLX400	4"
CTD-RLX500	5"
CTD-RLX600	6"

### Dimensions \* of Special Large Radius 90° Elbows

Trade Size	1"- 2 1/2"	1"- 3"	1"-4"	1"- 4"	1"- 5"	1"- 6"	1"- 6"
WHEN RADIUS A IN (INCH)	12"	15"	18"	24"	30"	42"	48"
WHEN RADIUS A IS (MM)	304.8	381.00	457.20	609.60	762.00	914.40	1219.20
OFFSET C IS	1'9"	2'0"	2'4"	2'11"	3'5"	3'11"	5'0"
STRAIGHT END D IS	9"	9"	10"	11"	11"	11"	12"
LENGTH UNBENT IS	3'0"	3'6"	4'0"	4'11"	5'9"	6'9"	8'4"

\* Dimensions apply to 90° elbows only. Inquire for other Radii  
\* Lead time to be advised by the factory at the time of order confirmation

#### Measuring Special Radius Elbows:

Locate center of Elbow B.  
Subtract straight section D from each end and final point E.  
Radius A is the distance between B and E.  
Offset C is measured as shows:

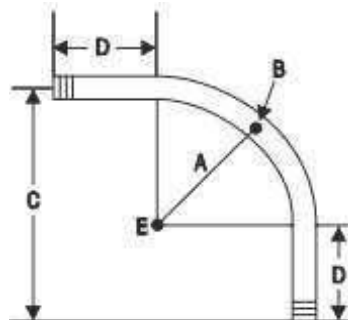

Straps

ONE HOLE STRAP



Code Malleable	Code Steel	Trade Size (INCH)
CTD-RSMI050	CTD-RS1050	1/2"
CTD-RSMI075	CTD-RS1075	3/4"
CTD-RSMI100	CTD-RS1100	1"
CTD-RSMI125	CTD-RS1125	1 1/4"
CTD-RSMI150	CTD-RS1150	1 1/2"
CTD-RSMI200	CTD-RS1200	2"
CTD-RSMI250	CTD-RS1250	2 1/2"
CTD-RSMI300	CTD-RS1300	3"
CTD-RSMI350	CTD-RS1350	3 1/2"
CTD-RSMI400	CTD-RS1400	4"
CTD-RSMI500	CTD-RS1500	5"
CTD-RSMI600	CTD-RS1600	6"

TWO HOLE STRAP



Code	Trade Size (INCH)
CTD-RS2050	1/2"
CTD-RS2075	3/4"
CTD-RS2100	1"
CTD-RS2125	1 1/4"
CTD-RS2150	1 1/2"
CTD-RS2200	2"
CTD-RS2250	2 1/2"
CTD-RS2300	3"
CTD-RS2350	3 1/2"
CTD-RS2400	4"
CTD-RS2500	5"
CTD-RS2600	6"

CLAMP BACK SPACER



Code	Trade Size (INCH)
CTD-RSMI050BS	1/2"
CTD-RSMI075BS	3/4"
CTD-RSMI100BS	1"
CTD-RSMI125BS	1 1/4"
CTD-RSMI150BS	1 1/2"
CTD-RSMI200BS	2"
CTD-RSMI250BS	2 1/2"
CTD-RSMI300BS	3"
CTD-RSMI350BS	3 1/2"
CTD-RSMI400BS	4"
CTD-RSMI500BS	5"
CTD-RSMI600BS	6"

Nipples

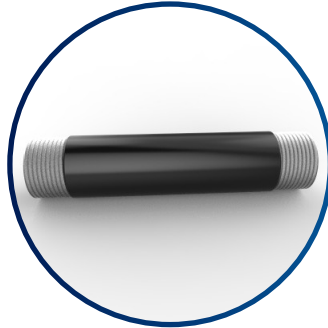

**NIPPLES 2"**

Item Code	Size
CTD-RNP050200	1/2" X 2"
CTD-RNP075200	3/4" X 2"
CTD-RNP100200	1" X 2"
CTD-RNP125200	1 1/4" X 2"
CTD-RNP150200	1 1/2" X 2"

**NIPPLES 2-1/2"**

Item Code	Size
CTD-RNP050212	1/2" X 2-1/2"
CTD-RNP075212	3/4" X 2-1/2"
CTD-RNP100212	1" X 2-1/2"
CTD-RNP125212	1 1/4" X 2-1/2"
CTD-RNP150212	1 1/2" X 2-1/2"
CTD-RNP200212	2" X 2-1/2"

**NIPPLES 3"**

Item Code	Size
CTD-RNP050300	1/2" X 3"
CTD-RNP075300	3/4" X 3"
CTD-RNP100300	1" X 3"
CTD-RNP125300	1 1/4" X 3"
CTD-RNP150300	1 1/2" X 3"
CTD-RNP200300	2" X 3"
CTD-RNP250300	2 1/2" X 3"

**NIPPLES 4"**

Item Code	Size
CTD-RNP050400	1/2" X 4"
CTD-RNP075400	3/4" X 4"
CTD-RNP100400	1" X 4"
CTD-RNP125400	1 1/4" X 4"
CTD-RNP150400	1 1/2" X 4"
CTD-RNP200400	2" X 4"
CTD-RNP250400	2 1/2" X 4"
CTD-RNP300400	3" X 4"
CTD-RNP350400	3-1/2" X 4"
CTD-RNP400400	4" X 4"

**NIPPLES 6"**

Item Code	Size
CTD-RNP050600	1/2" X 6"
CTD-RNP075600	3/4" X 6"
CTD-RNP100600	1" X 6"
CTD-RNP125600	1 1/4" X 6"
CTD-RNP150600	1 1/2" X 6"
CTD-RNP200600	2" X 6"
CTD-RNP250600	2 1/2" X 6"
CTD-RNP300600	3" X 6"
CTD-RNP350600	3-1/2" X 6"
CTD-RNP400600	4" X 6"

\* PVC Coating service is available for other fittings upon customer's request

Lock Nut & Conduit Hub

LOCK NUT



Item Code	Size
CTD-LKN050	1/2"
CTD-LKN075	3/4"
CTD-LKN100	1"
CTD-LKN125	1 1/4"
CTD-LKN150	1 1/2"
CTD-LKN200	2"
CTD-LKN250	2 1/2"
CTD-LKN300	3"
CTD-LKN350	3-1/2"
CTD-LKN400	4"

CONDUIT HUB



Item Code	Size
CTD-WH050	1/2"
CTD-WH075	3/4"
CTD-WH100	1"
CTD-WH125	1 1/4"
CTD-WH150	1 1/2"
CTD-WH200	2"
CTD-WH250	2 1/2"
CTD-WH300	3"
CTD-WH350	3-1/2"
CTD-WH400	4"

GROUNDED CONDUIT HUB



Item Code	Size
CTD-WH050B	1/2"
CTD-WH075B	3/4"
CTD-WH100B	1"
CTD-WH125B	1 1/4"
CTD-WH150B	1 1/2"
CTD-WH200B	2"
CTD-WH250B	2 1/2"
CTD-WH300B	3"
CTD-WH350B	3-1/2"
CTD-WH400B	4"

## Conduit Hanger

Conduit Hanger



Item Code	Size
CTD-HAN050	1/2"
CTD-HAN075	3/4"
CTD-HAN100	1"
CTD-HAN125	1 1/4"
CTD-HAN150	1 1/2"
CTD-HAN200	2"
CTD-HAN250	2 1/2"
CTD-HAN300	3"
CTD-HAN350	3-1/2"
CTD-HAN400	4"

Strut Clamp



Item Code	Size
CTD-USC050	1/2"
CTD-USC075	3/4"
CTD-USC100	1"
CTD-USC125	1 1/4"
CTD-USC150	1 1/2"
CTD-USC200	2"
CTD-USC250	2 1/2"
CTD-USC300	3"
CTD-USC350	3-1/2"
CTD-USC400	4"

## Conduit Body

Conduit Body Type LB



Item Code	Size
CTD-LB-50-GG	1/2"
CTD-LB-75-GG	3/4"
CTD-LB-100-GG	1"
CTD-LB-125-GG	1 1/4"
CTD-LB-150-GG	1 1/2"
CTD-LB-200-GG	2"
CTD-LB-250-GG	2 1/2"
CTD-LB-300-GG	3"
CTD-LB-350-GG	3-1/2"
CTD-LB-400-GG	4"

Conduit Body Type LL



Item Code	Size
CTD-LL-50-CG	1/2"
CTD-LL-75-CG	3/4"
CTD-LL-100-CG	1"
CTD-LL-125-CG	1 1/4"
CTD-LL-150-CG	1 1/2"
CTD-LL-200-CG	2"
CTD-LL-250-CG	2 1/2"
CTD-LL-300-CG	3"
CTD-LL-350-CG	3-1/2"
CTD-LL-400-CG	4"

Conduit Body Type LR



Item Code	Size
CTD-LR-50-GG	1/2"
CTD-LR-75-GG	3/4"
CTD-LR-100-GG	1"
CTD-LR-125-GG	1 1/4"
CTD-LR-150-GG	1 1/2"
CTD-LR-200-GG	2"
CTD-LR-250-GG	2 1/2"
CTD-LR-300-GG	3"
CTD-LR-350-GG	3-1/2"
CTD-LR-400-GG	4"



## Conduit Body

### Conduit Body Type T



Item Code	Size
CTD-T-50-GG	1/2"
CTD-T-75-GG	3/4"
CTD-T-100-GG	1"
CTD-T-125-GG	1 1/4"
CTD-T-150-GG	1 1/2"
CTD-T-200-GG	2"
CTD-T-250-GG	2 1/2"
CTD-T-300-GG	3"
CTD-T-350-GG	3-1/2"
CTD-T-400-GG	4"

### Conduit Body Type C



Item Code	Size
CTD-C-50-GG	1/2"
CTD-C-75-GG	3/4"
CTD-C-100-GG	1"
CTD-C-125-GG	1 1/4"
CTD-C-150-GG	1 1/2"
CTD-C-200-GG	2"
CTD-C-250-GG	2 1/2"
CTD-C-300-GG	3"
CTD-C-350-GG	3-1/2"
CTD-C-400-GG	4"

### Conduit Body Type X



Item Code	Size
CTD-X-50-GG	1/2"
CTD-X-75-GG	3/4"
CTD-X-100-GG	1"
CTD-X-125-GG	1 1/4"
CTD-X-150-GG	1 1/2"
CTD-X-200-GG	2"
CTD-X-250-GG	2 1/2"
CTD-X-300-GG	3"
CTD-X-350-GG	3-1/2"
CTD-X-400-GG	4"

Liquidtight Connectors

Straight



Item Code	Size
CTD-CFLT050	1/2"
CTD-CFLT075	3/4"
CTD-CFLT100	1"
CTD-CFLT125	1 1/4"
CTD-CFLT150	1 1/2"
CTD-CFLT200	2"
CTD-CFLT250	2 1/2"
CTD-CFLT300	3"
CTD-CFLT350	3-1/2"
CTD-CFLT400	4"

Straight W/Ground



Item Code	Size
CTD-CFLT050-GR	1/2"
CTD-CFLT075-GR	3/4"
CTD-CFLT100-GR	1"
CTD-CFLT125-GR	1 1/4"
CTD-CFLT150-GR	1 1/2"
CTD-CFLT200-GR	2"
CTD-CFLT250-GR	2 1/2"
CTD-CFLT300-GR	3"
CTD-CFLT350-GR	3-1/2"
CTD-CFLT400-GR	4"

Liquidtight Connectors

90°



Item Code	Size
CTD-CFLT9050	1/2"
CTD-CFLT9075	3/4"
CTD-CFLT9100	1"
CTD-CFLT9125	1 1/4"
CTD-CFLT9150	1 1/2"
CTD-CFLT9200	2"
CTD-CFLT9250	2 1/2"
CTD-CFLT9300	3"
CTD-CFLT9350	3-1/2"
CTD-CFLT9400	4"

90° W/Ground



Item Code	Size
CTD-CFLT9050-GR	1/2"
CTD-CFLT9075-GR	3/4"
CTD-CFLT9100-GR	1"
CTD-CFLT9125-GR	1 1/4"
CTD-CFLT9150-GR	1 1/2"
CTD-CFLT9200-GR	2"
CTD-CFLT9250-GR	2 1/2"
CTD-CFLT9300-GR	3"
CTD-CFLT9350-GR	3-1/2"
CTD-CFLT9400-GR	4"

PVC Coated Unions

UNF - Female - Female



Item Code	Size
CTD-UNF-050	1/2"
CTD-UNF-075	3/4"
CTD-UNF-100	1"
CTD-UNF-125	1 1/4"
CTD-UNF-150	1 1/2"
CTD-UNF-200	2"
CTD-UNF-250	2 1/2"
CTD-UNF-300	3"
CTD-UNF-350	3-1/2"
CTD-UNF-400	4"
CTD-UNF-500	5"
CTD-UNF-600	6"

UNY - Female - Male



Item Code	Size
CTD-UNY-050	1/2"
CTD-UNY-075	3/4"
CTD-UNY-100	1"
CTD-UNY-125	1 1/4"
CTD-UNY-150	1 1/2"
CTD-UNY-200	2"
CTD-UNY-250	2 1/2"
CTD-UNY-300	3"
CTD-UNY-350	3-1/2"
CTD-UNY-400	4"
CTD-UNY-500	5"
CTD-UNY-600	6"

\* PVC Coating service is available for other fittings upon customer's request

PVC Coated Sealing Fitting

EYS Female Hubs - Vertical



Item Code	Size
CTD-EYS1	1/2"
CTD-EYS2	3/4"
CTD-EYS3	1"

EYS Female - Male Hubs



Item Code	Size
CTD-EYS16	1/2"
CTD-EYS26	1"
CTD-EYS36	4"

EYS Female Hubs - Ver. & Hor.



Item Code	Size
CTD-EYS11	1/2"
CTD-EYS21	3/4"
CTD-EYS31	1"
CTD-EYS41	1 1/4"
CTD-EYS51	1 1/2"
CTD-EYS61	2"
CTD-EYS71	2 1/2"
CTD-EYS81	3"
CTD-EYS101	4"

EYS Male - Female Hubs



Item Code	Size
CTD-EYS116	1/2"
CTD-EYS216	3/4"
CTD-EYS316	1"
CTD-EYS416	1 1/4"
CTD-EYS516	1 1/2"
CTD-EYS616	2"
CTD-EYS716	2 1/2"
CTD-EYS816	3"
CTD-EYS1016	4"

## PVC Coated Strut Channels &amp; U Bolts

## Strut Channels



Item Code	Inch	MM	Gauge	MM
CTD-USC-C025	1 <sup>5</sup> / <sub>8</sub> X 1 <sup>5</sup> / <sub>8</sub> "	41 X 41	12	2.5
CTD-USC-C020	1 <sup>5</sup> / <sub>8</sub> X 1 <sup>5</sup> / <sub>8</sub> "	41 X 41	14	2.0
CTD-USC-C015	1 <sup>5</sup> / <sub>8</sub> X 1 <sup>5</sup> / <sub>8</sub> "	41 X 41	16	1.5
CTD-USC-C012	1 <sup>5</sup> / <sub>8</sub> X T"	41 X 41	18	1.2
CTD-USC-C125	1 <sup>5</sup> / <sub>8</sub> X T"	41 X 21	12	2.5
CTD-USC-C120	1 <sup>5</sup> / <sub>8</sub> X T"	41 X 21	14	2.0
CTD-USC-C115	1 <sup>5</sup> / <sub>8</sub> X T"	41 X 21	16	1.5
CTD-USC-C112	1 <sup>5</sup> / <sub>8</sub> X T"	41 X 21	18	1.2

\* Standard length 10ft/3.0 meter

\*\* Other length & thickness available



Masjid Al-Haram Expansion Project KSA



King Abdulaziz Airport KSA



Jewel of the Creek UAE



Aramco Jazan Refinery KSA



Expo 2020 Project UAE



Mohamed Bin Raschid City UAE



The Point Mall Palm Jumeirah UAE



Abdali Mall Jordan



Akoya Oxigen UAE



American University of Sharjah UAE



Bahrain International Airport Expansion



Hamad International Airport Qatar



Waterfront City 2 Lebanon



Cairo Intl Airport Egypt



Riyadh Metro KSA



Basra Sports City Iraq



New Administrative Capital Egypt



Al Amiri Hospital Expansion Kuwait



Kingdom Tower KSA



Doha Festival City Qatar





Al Ain Hospital UAE



Al Dabbiya Surface Facilities Phase 3 UAE



Al Habtoor City Dubai UAE



Burjeel Medical City UAE



Cardiology Center Bahrain



Doha Metro Qatar



Dubai Hills Mall UAE



Emerald Palace Kempinski Dubai UAE



Fly Dubai Headquarters UAE



Wafi Hotel Complex and Mall Expansion UAE



International Tube & Conduit Company Ltd.



T: +966 12 2889198 - T: +966 12 2885935 - P.O. Box: 10374 Jeddah 21433 - KSA  
E-mail: [sales@itcc-group.com](mailto:sales@itcc-group.com) - [www.itcc-group.com](http://www.itcc-group.com)